



附件 2 用户手册
Appendix 2 User Manua





MYGALE
M14-F4 GEELY
USER MANUAL



MYGALE
Technopole
58470 Magny-Cours
France
Tel : +33 (0)3 86 21 86 21
Fax : +33 (0)3 86 21 86 22

Version: V1.2

0.0 CONTENTS

0.0 CONTENTS	2
1.0 CAR VIEWS	3
2.0 CAR SPECIFICATIONS	4
2.1 Dimensions	4
2.2 Weight	4
2.3 Supplied Parts: Partners	5
3.0 SET UP AND OPTIONS	6
3.1 Geometry information (in baselineset-up)	6
3.2 Set Up Adjustment	7
3.3 Kinematics - Graphical Representation	18
3.4 Springs	22
3.5 Dampers	23
3.6 Anti-Roll Bars	25
3.7 Aero Set Up	27
3.8 Brake bias	29
3.9 Pedal box adjustment	30
3.10 Set-up sheet Baseline Proposal	34
3.11 Ballast	35
3.12 Paddleshift	36
3.13 Gear box ratios	38
3.14 Data acquisition	39
3.15 Brake pads	39
3.16 Steering system adjustments	39
3.17 Radiator protection grille	40
4.0 ASSEMBLY AND MAINTENANCE	41
4.1 Engine	41
4.2 Transmission	41
4.3 Steering System	43
4.4 Hub Assembly	45
4.5 Wishbones	46
4.6 Wheel Cables	46
4.7 Heat protection	47
4.8 Brake line protection	47
4.9 Electricity	47
4.10 Wings	47
4.11 Head restraint	48
4.12 Monocoque Chassis and Crash Boxes	48
4.13 Bodywork repairs	49
4.14 Bodywork adjustment	49
4.15 Extractible seat cut for loom	49
4.16 Fire extinguisher	50
4.17 Markings and holograms	50
4.18 Screws	50
4.19 Fuel system	51
4.20 Cooling system	52
4.21 Filling fluids	55
4.22 Accident data recorder	56
4.23 Assembly of the starter	56
4.24 Exploitation tools	57

5.0 ANNEXES	61
5.1 Tightening torques (general)	61
5.2 Tightening torques (F4 mounting)	62

1 . 0 CAR VIEWS

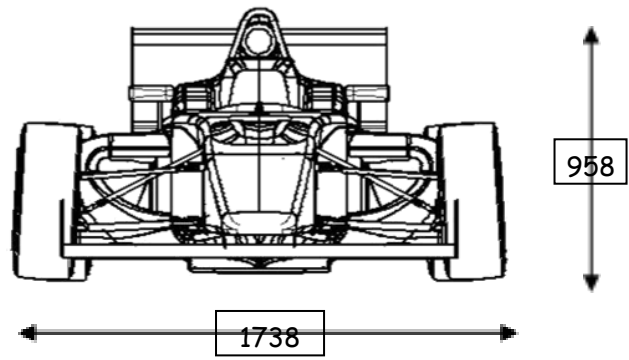
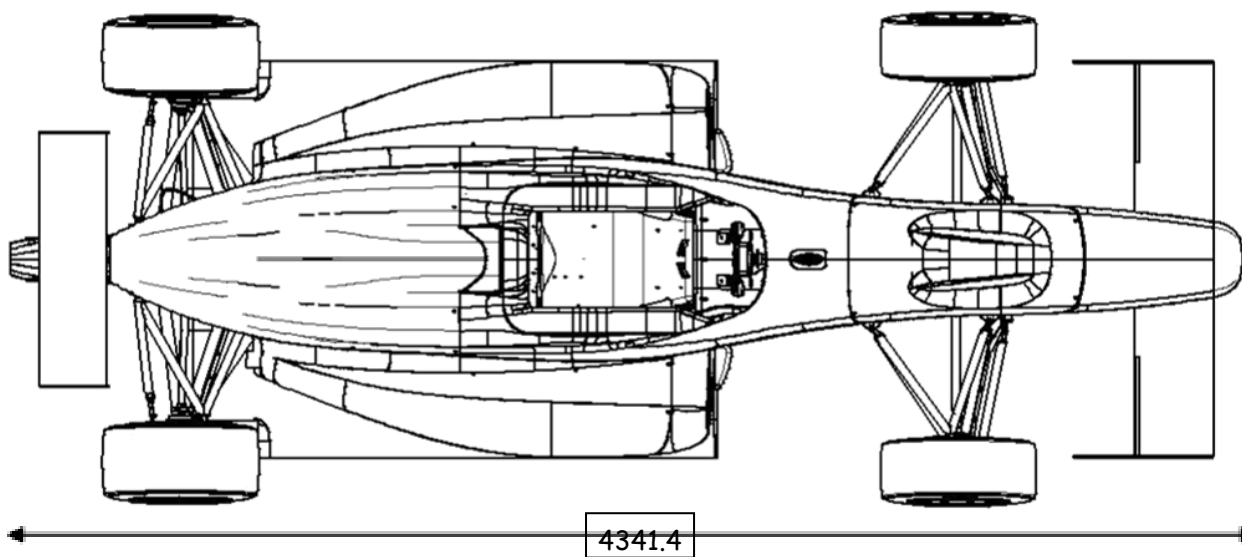
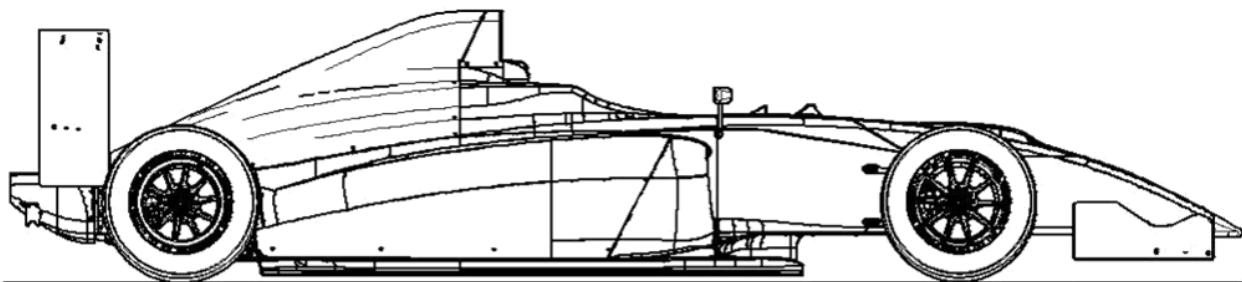

2.0 CAR SPECIFICATIONS

2.1 DIMENSIONS

Description		Reference Dimensions
Length	mm	4341
Height	mm	958
Front ride height	mm	20
Rear ride height	mm	30
Wheelbase	mm	2742
Front overhang	mm	1000
Rear overhang	mm	600
Front overall width	mm	1725 *
Rear overall width	mm	1715 *
Front track	mm	1493.5
Rear track	mm	1430.4
Front wing assy width	mm	1400
Rear wing assy width	mm	898

* depending tyres

2.2 WEIGHT

The minimum allowed weight is specified by sporting regulations of the championship.

The weight of the car should be adjusted by mean of appropriate ballast to ensure that the specified minimum weight is reached with the driver at any time during the event

2.3 SUPPLIED PARTS: PARTNERS

Gearbox, driveshaft: Sadev



Steering rack: Titan



Springs, dampers: Sachs



Fuell cell, fuel pump: Premier Fuel



Brake pads: Ferodo



Brake discs, callipers: Brembo



Extinguisher : OMP



Harness : TRS Motrosports



Rims : Team Dynamics



3.0 SET UP AND OPTIONS

3.1 GEOMETRY INFORMATION (IN BASELINE SET- UP)

The standard set up of the car is:

	dimension	FRONT	REAR
Ride Height	mm	24	37
Camber	deg	-3.3	-2.2
Toe	deg	0.00	0.00
Castor	deg	8.21	-22.81
Castor Offset (wheel centre)	mm	5.64	---
Castor Offset (ground)	mm	31.23	---
King Pin	deg	15.46	---
King Pin Offset (wheel centre)	mm	69.1	---
King Pin Offset (ground)	mm	15.4	---
Damper-Spring / Wheel	ratio	0.68	0.71
Anti Roll Bar (deg) / Wheel	ratio	0.69	0.48
Anti Dive	%	14.45	22.13
Ackermann	%	19.9	---
Roll Center Z	mm	17.8	34.5
Mechanical trail*	mm	30.87	

*Mechanical trail : The perpendicular distance in side elevation between the steering axis and the centre of tyre contact. It is considered positive when the steering axis forward of the tyre contact centre and negative when it is rearward.

3.2 SET UP ADJUSTMENT

Values are theoretical, assembly dispersion is possible.

3.2.1 RIDE HEIGHT CHECK & ADJUSTMENT

The reference points for calculating the ride height are shown below.

The vehicle reference plane is the lower side of the wood floor. The skid block is below this. The choice of ride height needs to take account of the skid block thickness which is a maximum of 5mm below the reference plane (and minimum 2mm).

The diagrams refer to the dimensions from the chassis reference point to the reference plane.

At the front two ride height adjustment screws (F.41.35.001) must be fix on the two reference pads which are machined into the upper surface of the monocoque and are accessible with the damper cover removed.

At the rear the reference surfaces are machined pads on the gearbox upper surface, at the level of the damper bracket and are accessible with the engine cover removed.

Front reference

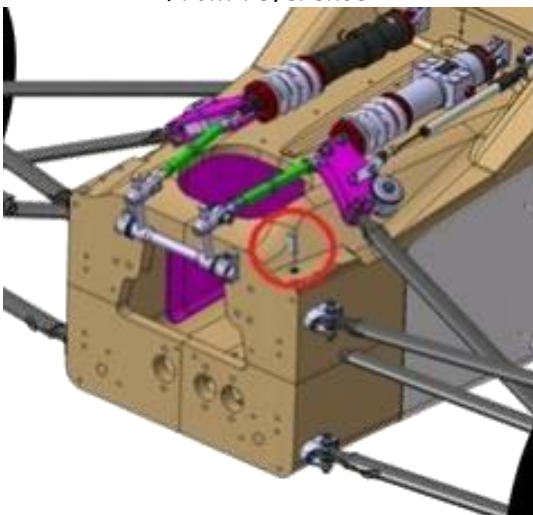

Rear reference

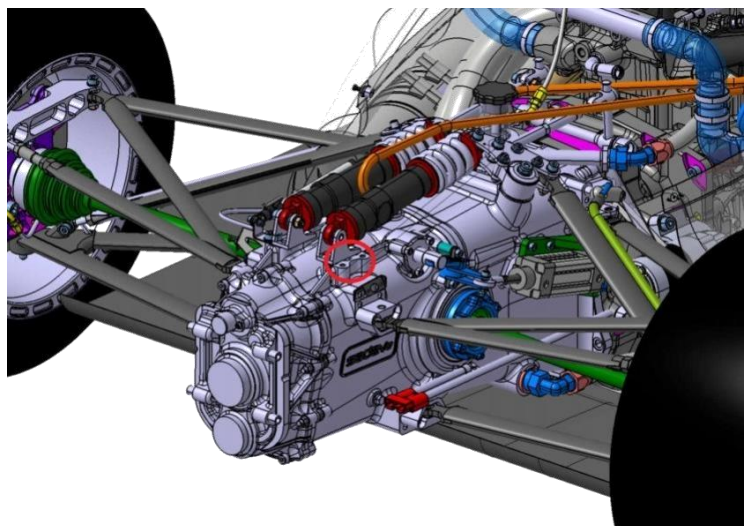

The front reference dimension A1 is 441mm.
The rear reference dimension A2 is 369mm.

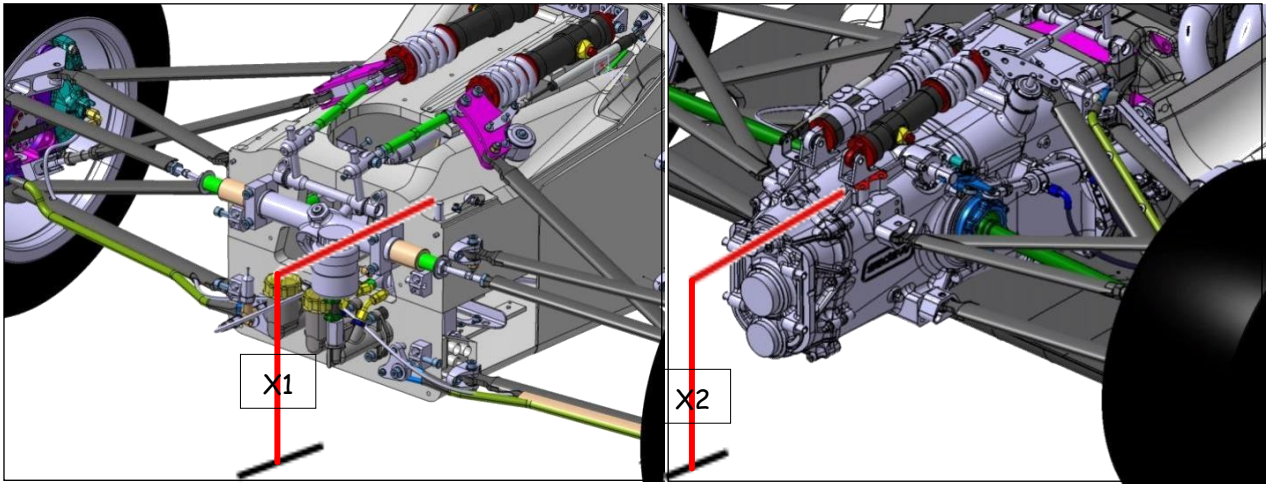
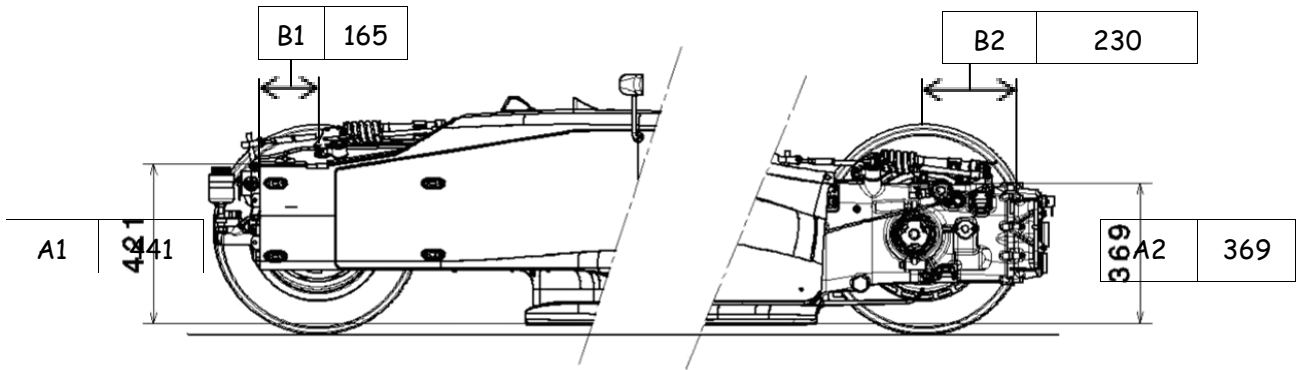

To set up front and rear ride height values at the level of the front and rear axle centre lines (H1 and H2 respectively), use the following calculation:

$$X1 = A1 \cdot \cos(\alpha) - B1 \cdot \sin(\alpha) + H1$$

$$X2 = A2 \cdot \cos(\alpha) + B2 \cdot \sin(\alpha) + H2$$

(Dimensions in mm)

Where α is the car pitch angle, $\alpha = \arcsin((H2-H1)/2741.6)$ in rad.

Ride height adjustment:

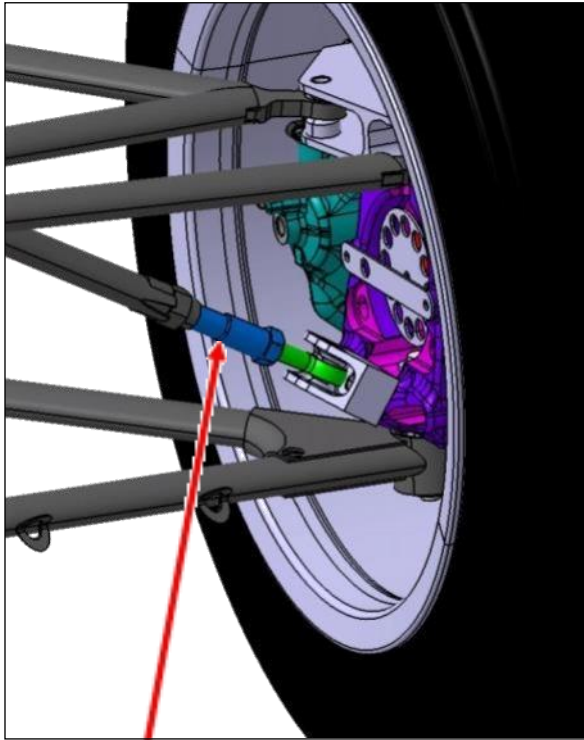

Front ride height adjustment

Lengthen adjuster to raise car.
Shorten adjuster to lower car

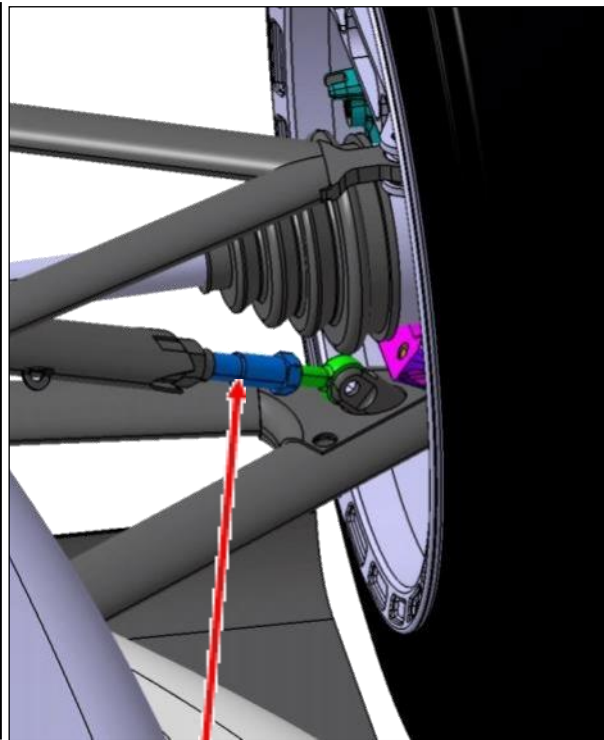

Rear ride height adjustment

Lengthen adjuster to raise car.
Shorten adjuster to lower car

Front:

Lengths (ball centre to ball centre) for a 20mm ride height: Pushrod 554.6mm.

1 face on the adjuster changes the ride height by 0.95mm.

1 turn on the adjuster changes the ride height by 5.70mm.

For 1mm ride height, 1/6 turn on the adjuster.

Rear:

Lengths (ball centre to ball centre) for a 30mm ride height: Pushrod 527.5mm.

1 face on the adjuster changes the ride height by 1.00mm.

1 turn on the adjuster changes the ride height by 6.00mm.

For 1mm ride height, 1/6 turn on the adjuster.

3. 2. 2 CASTOR CHECK & ADJUSTMENT

The castor angle is the angle, in side elevation, between the steering axis and the vertical. It is considered positive when the steering axis is inclined rearward.

You can check the castor angle in the same way in the front and in the rear suspension. The castor angle can be calculated as follows:

Measure the angle of the steering arm plane for the front (or the wishbone mount plane for the rear) to the horizontal; this is the measured castor angle (MCA). Positive inclined down to rear, negative inclined down to front. Calculate the true castor angle (TCA) as following:

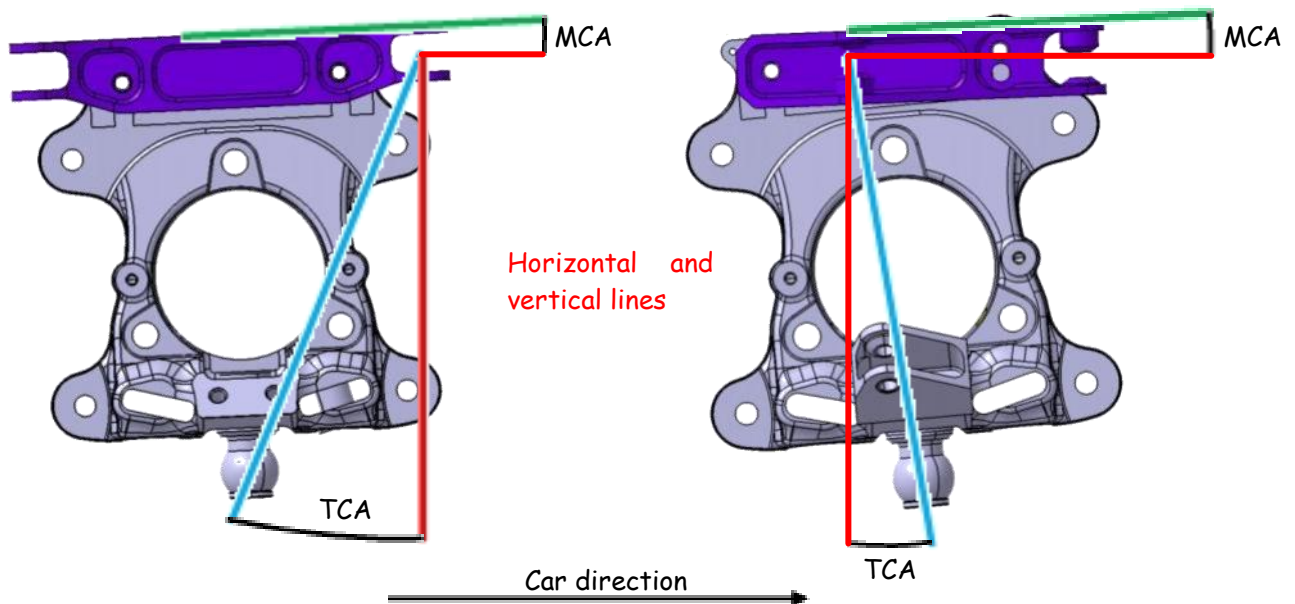

	Front Castor Angle	Rear Castor Angle
True castor angle	= $MCA + 7.08^\circ$	= $MCA - 25.41^\circ$
Base settings	8.21°	-22.81°
Base set up length, wishbone ball centre to ball centre	556.4mm	578.9mm

The Castor angle influences the Castor Offset, the Mechanical Trail and therefore the force to turn the wheel.

Castor Offset, (mm)

The distance in side elevation between the point where the steering axis intersects the ground, and the centre of tyre contact. The offset is considered positive when the intersection point is forward of the tyre contact centre and negative when it is rearward. (Base setting: FRT=31.23mm)

Mechanical Trail, (mm)

The perpendicular distance in side elevation between the steering axis and the centre of tyre contact. It is considered positive when the steering axis is forward of the tyre contact centre and negative when it is rearward. (Base setting: FRT=30.87mm)

The Castor Offset is along the ground plane while the Mechanical Trail is perpendicular to the steering axis.

Castor adjustment:

Adjust the castor angle with the rod end bearings as shown in the following pictures:

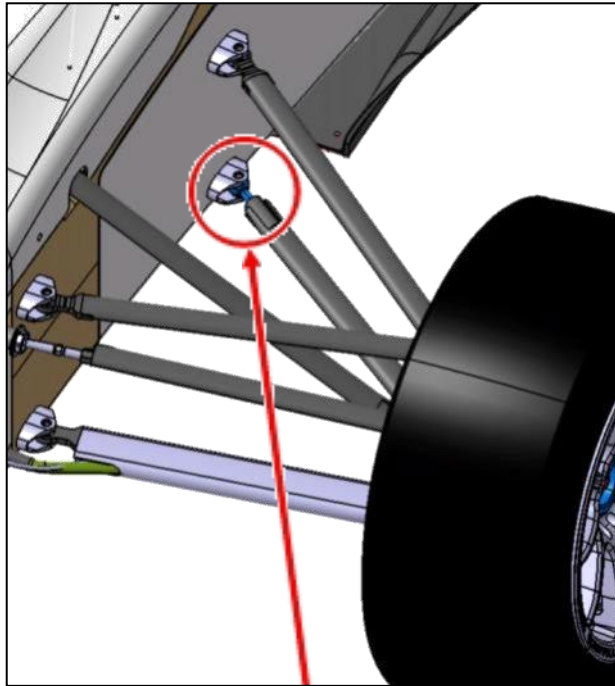

Front castor adjustment

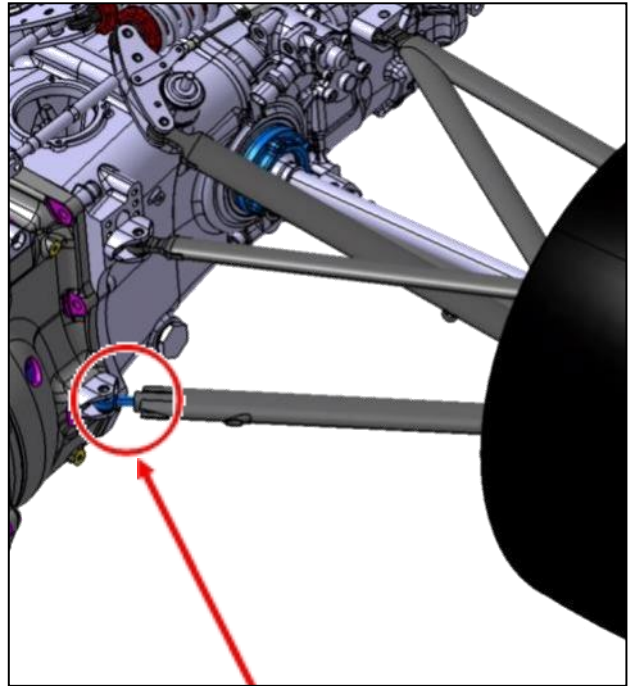

Rear castor adjustment

3.2. 3 CAMBER ADJUSTMENT

The Camber Angle is the inclination of the wheel plane to the vertical. It is considered positive when the wheel leans outward at the top and negative when it leans inward.

The Camber can be adjusted by releasing the fixing bolts and adding or removing shims between the steering arm and the upright. A change of shim has no influence on the toe setting.

Front (Rear similar)

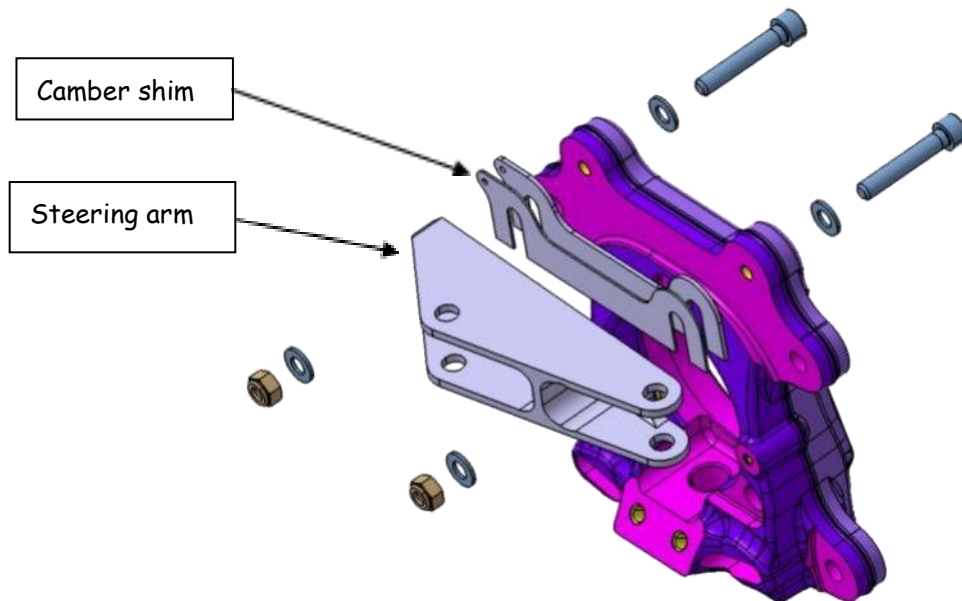

Available shims:

Part Number	Description
F.41.14.055.A	Camber shim 1 mm
F.41.14.056.A	Camber shim 1.5 mm
F.41.14.057.A	Camber shim 2 mm
F.41.14.058.A	Camber shim 4 mm

Front

Recommended base setting: $-3,3^\circ$, 2mm of shim

Adjustment: $0.325^\circ/\text{mm}$
1.5mm for 0.5°

Rear

Recommended base setting: -2.2° , 4.5mm of shim (2mm + 1.5mm+1mm)

Adjustment: $0.300^\circ/\text{mm}$
1.5mm for 0.5°

3.2. 4 TOE CHECK & ADJUSTMENT

The toe angle is the angle between a longitudinal axis of the vehicle and the line of intersection of the wheel plane and the road surface. The wheel is "toed-in" if the forward portion of the wheel is turned towards a central longitudinal axis of the vehicle, and "toed-out" if turned away.

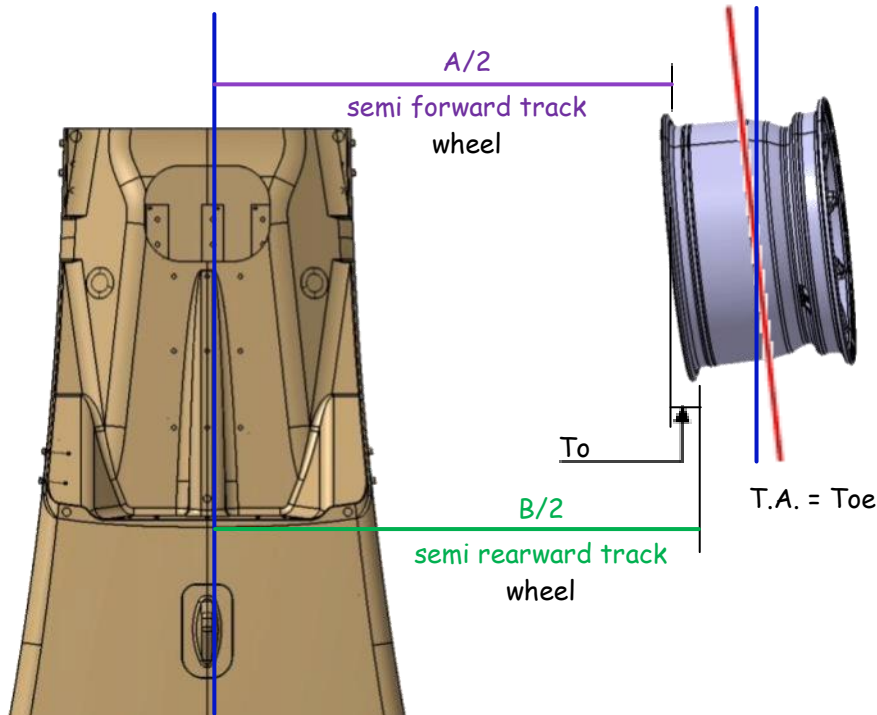

Checking the distance between the wheel forward and rearward points in the front suspension is possible to measure the Toe.

The Toe can be measured with the following formula:

$$\text{Toe} = B/2 - A/2$$

The correlation between degrees and the value $B/2 - A/2$ is :

$B/2 - A/2$ (mm)	Toe (deg)
18	3
12	2
6	1
0	0
-6	-1
-12	-2
-18	-3

In this table, negative toe corresponds to "toe out", positive toe corresponds to "toe In". The Toe angle can be adjusted with the track rod.

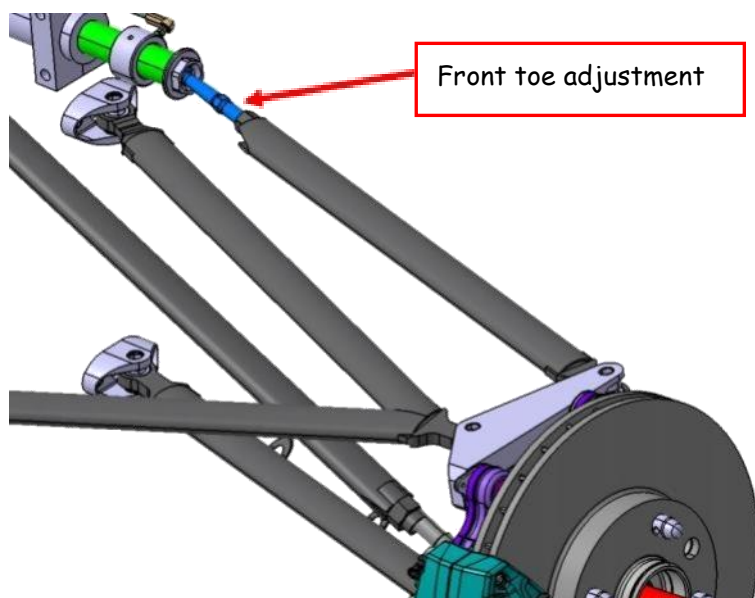
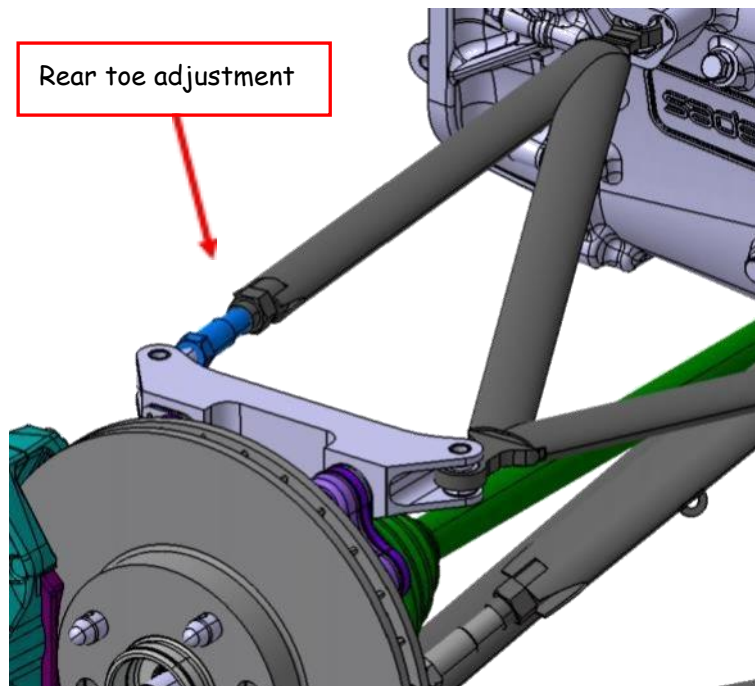

Base starting set up lengths for toe adjustment (ball centre to ball centre)

Front trackrod assembly: 474.9mm for toe 0° (and 0mm)
 ±1 turn on the bearing = ±3.84mm
 ±1 face turn on the bearing = ±0.64mm
 For 1mm toe: 1.6 faces bearing

Rear trackrod assembly: 478.7mm for toe 0° (and 0mm)
 ±1 turn on the adjuster = ±4.70mm
 ±1 face turn on the adjuster = ±0.43mm
 For 1mm toe: 2.4 faces adjuster

3.2. 5 SUSPENSION POINTS

Front suspension points

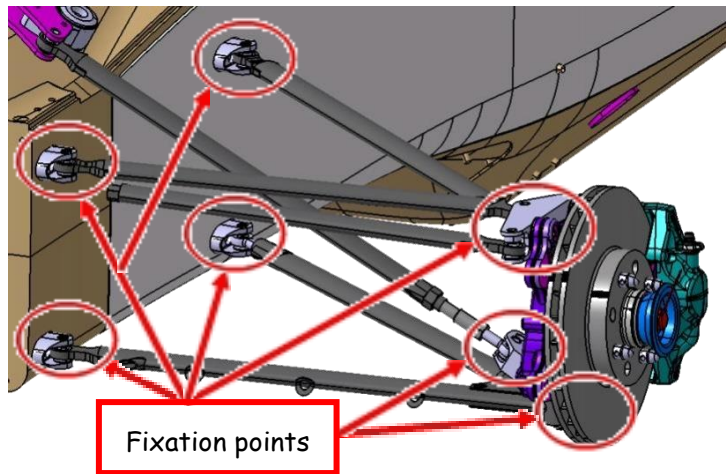

The following picture shows the mandatory position of the front upright points:

Ref. F.41.14.063.B (x4)

Ref. F.41.14.064.B (x2)

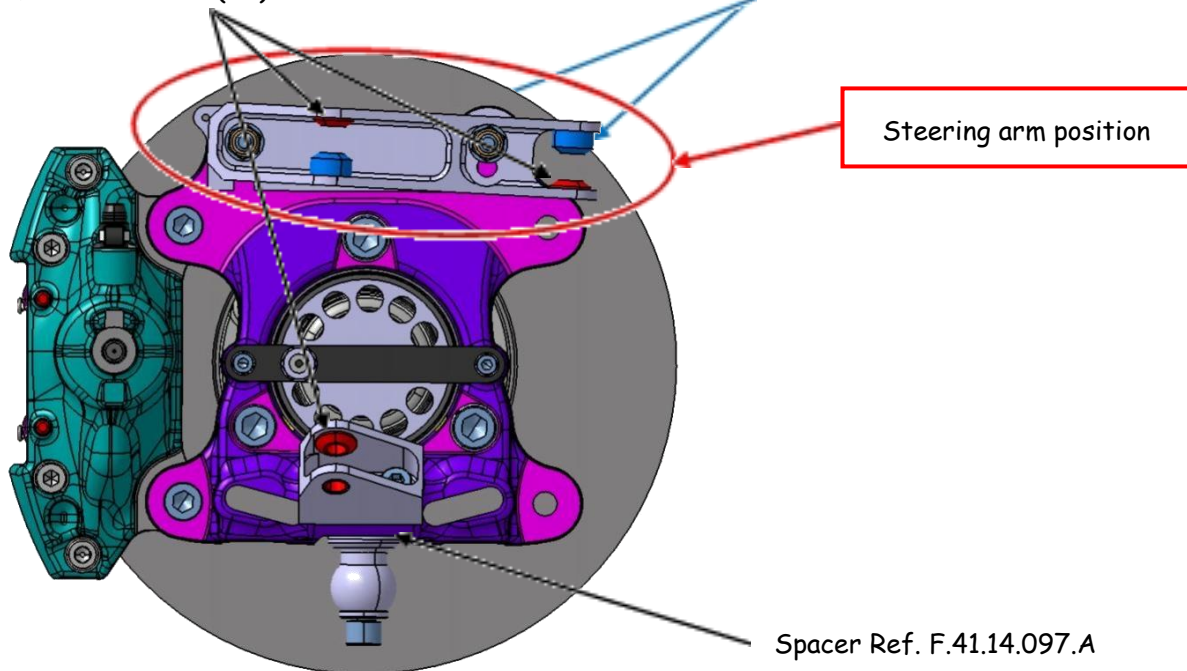

Rear suspension points

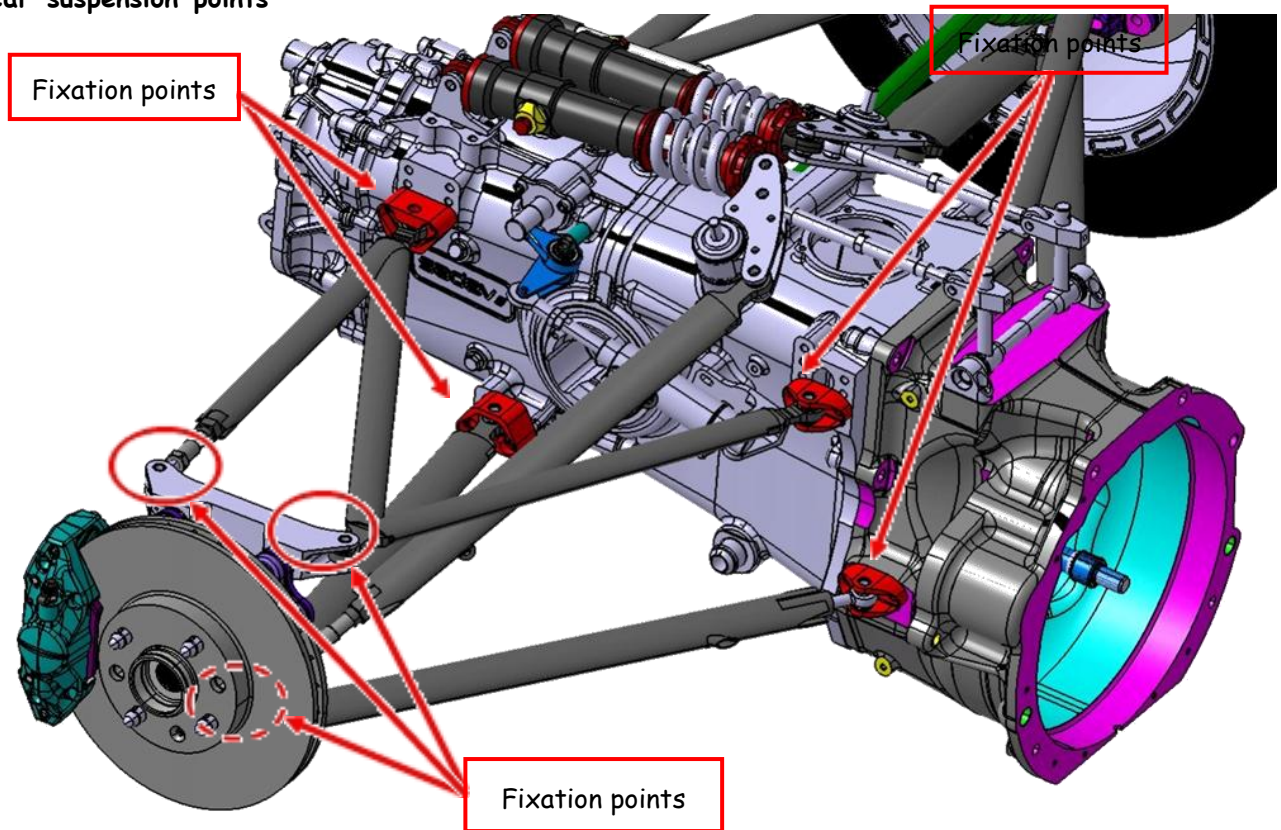

The following picture shows the mandatory position of the rear wishbone brackets:

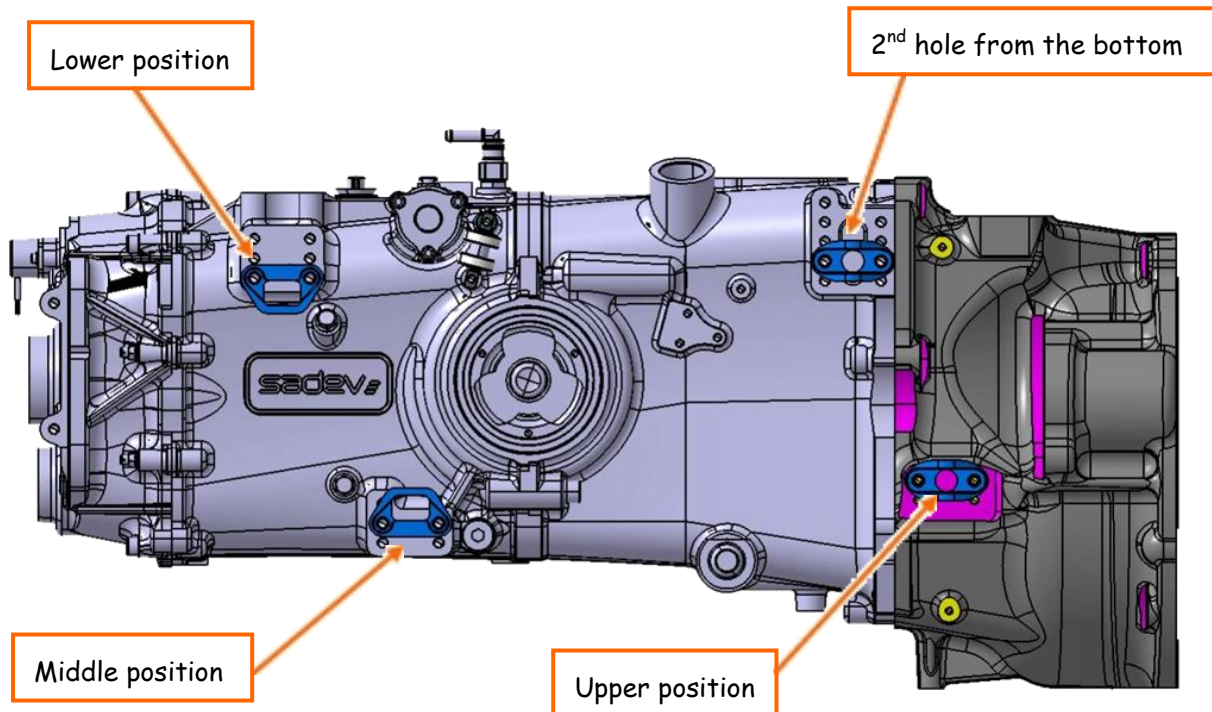

The following picture shows the mandatory position of the rear upright points:

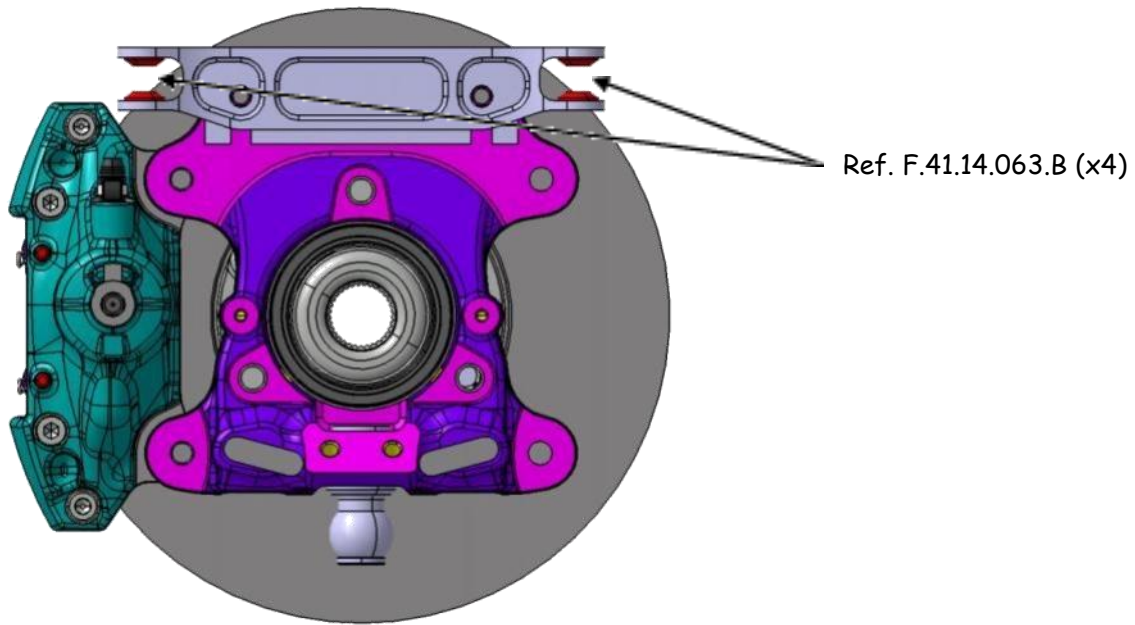

3. 3 KINEMATICS - GRAPHICAL REPRESENTATION

All the following graphs represent the kinematics in standard setup.

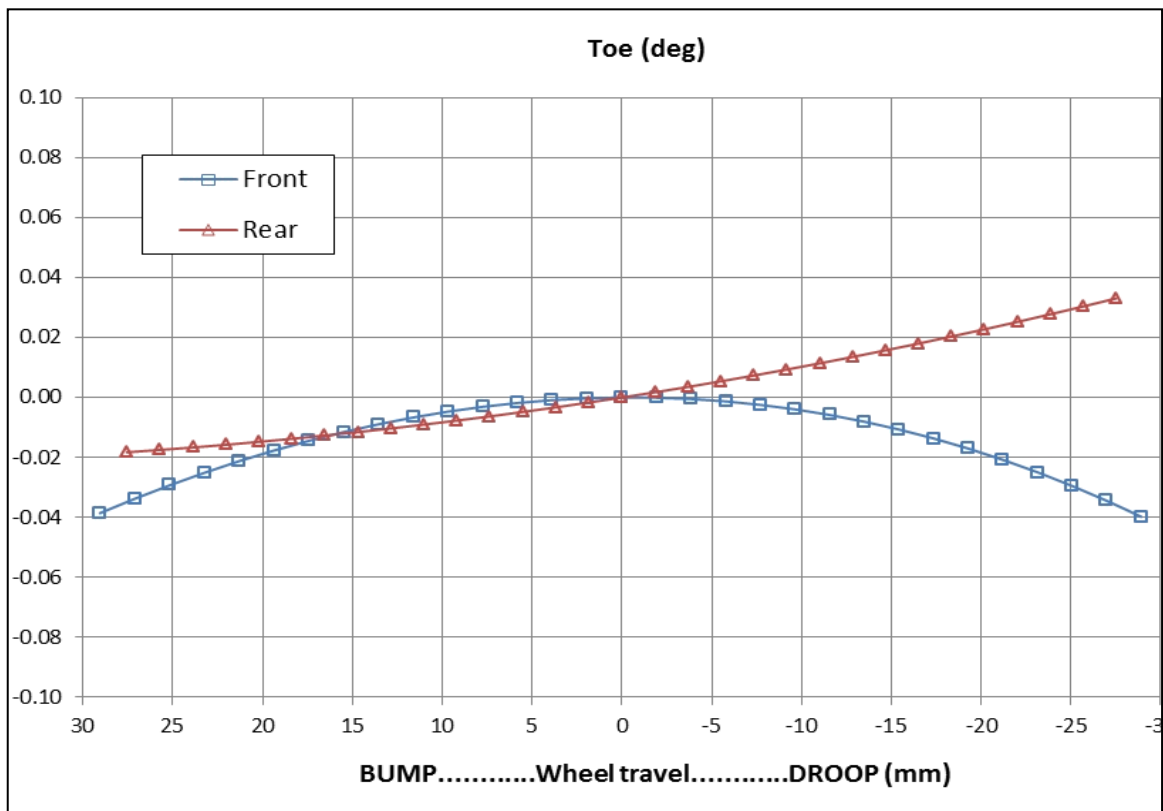
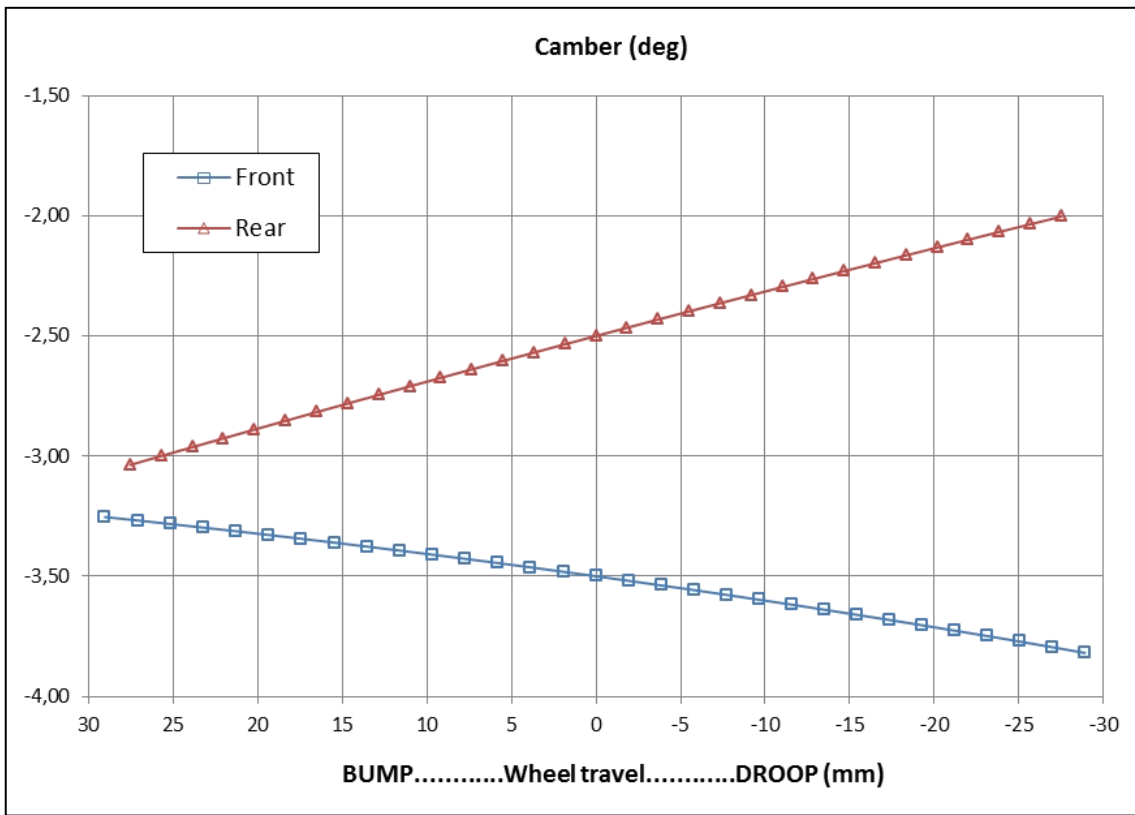

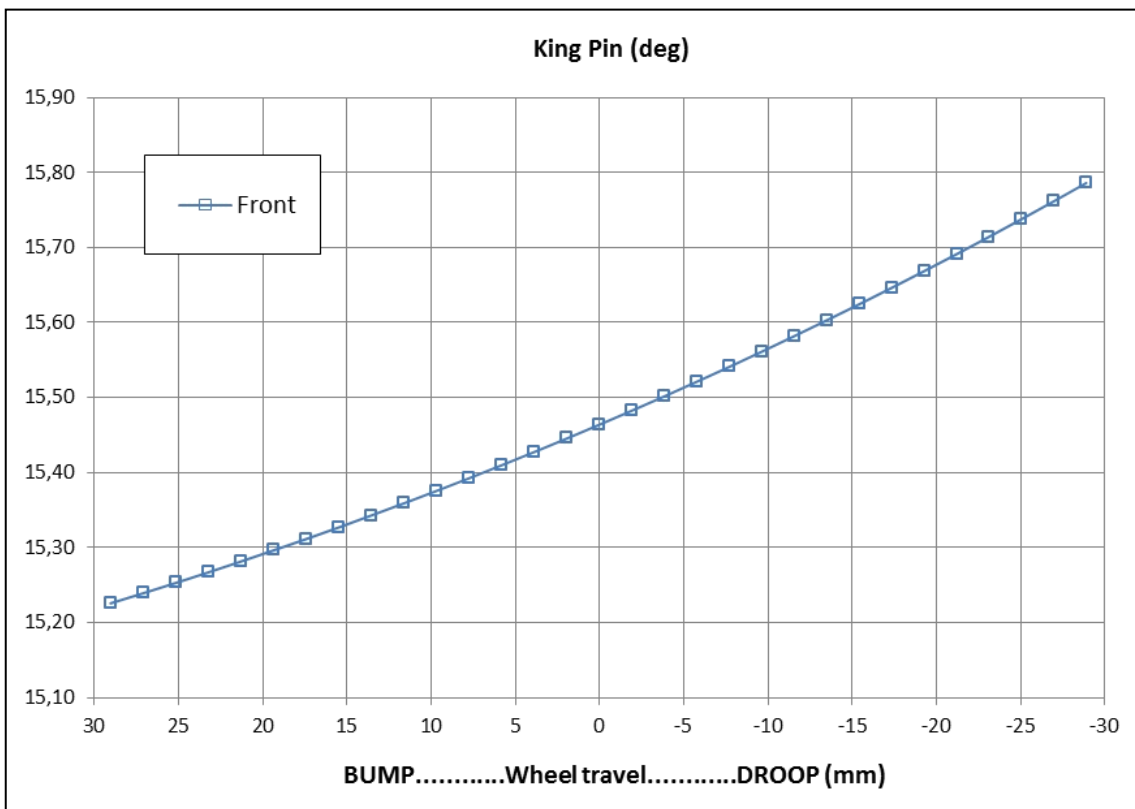
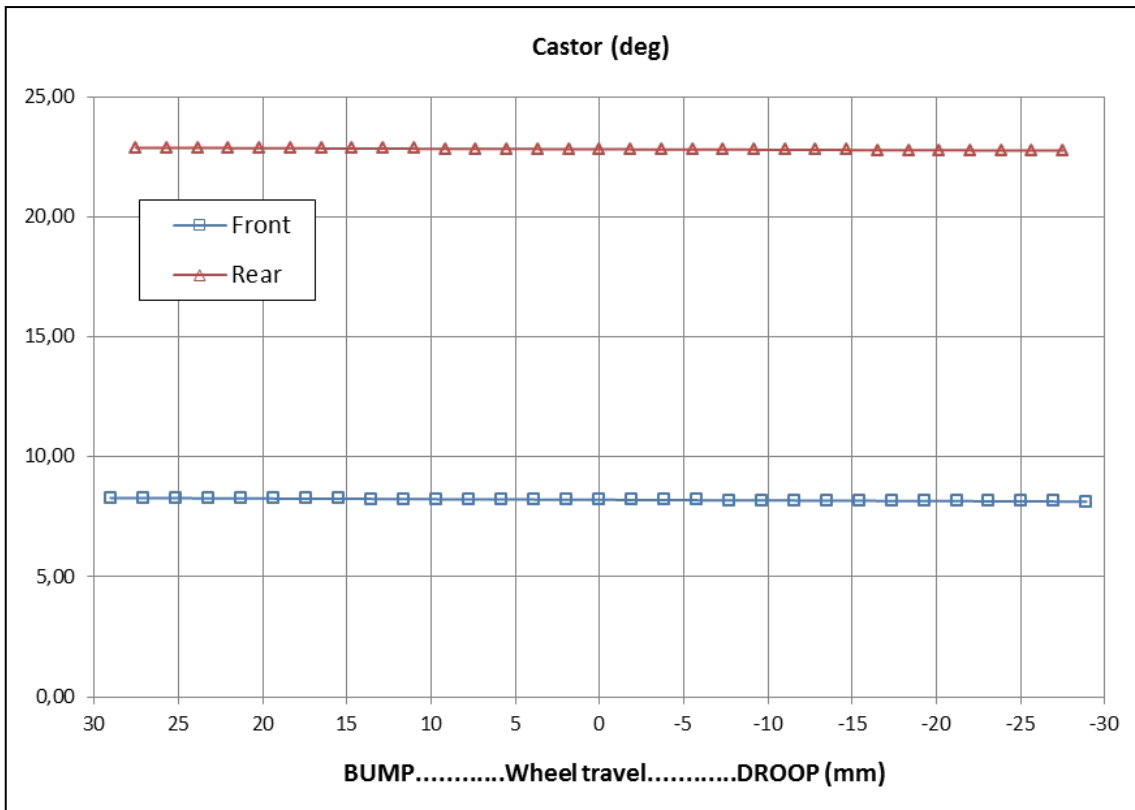

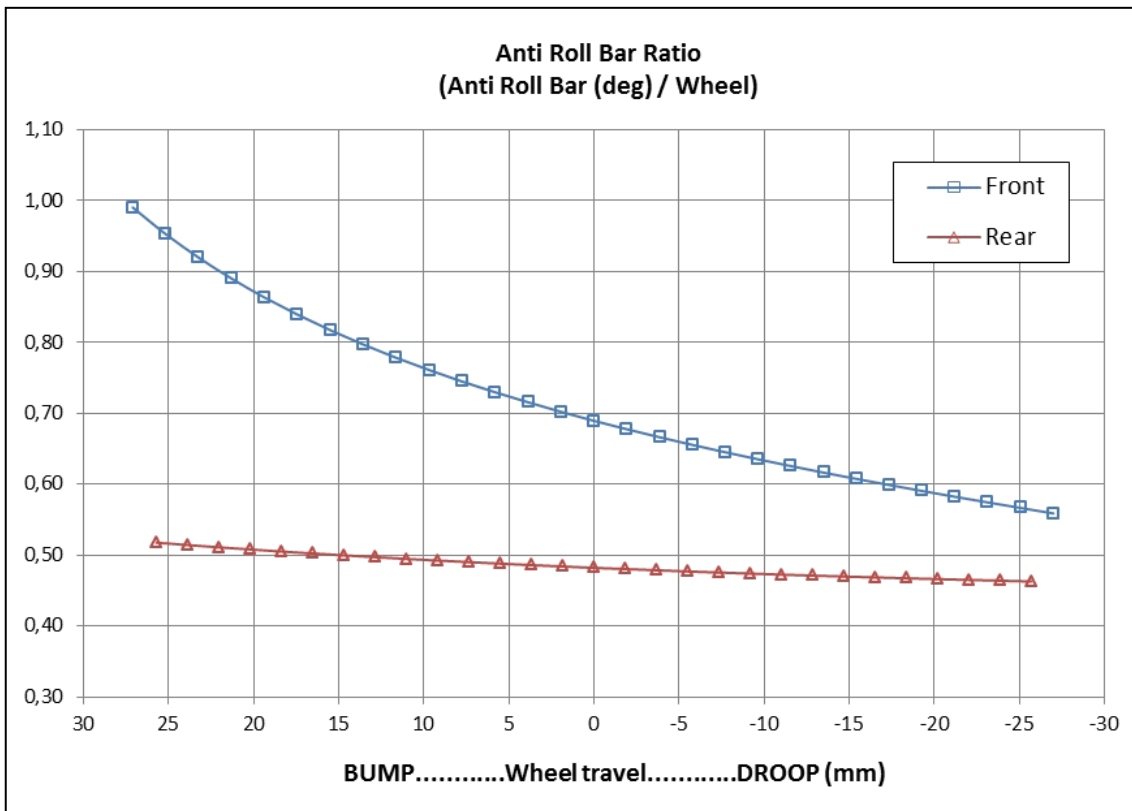
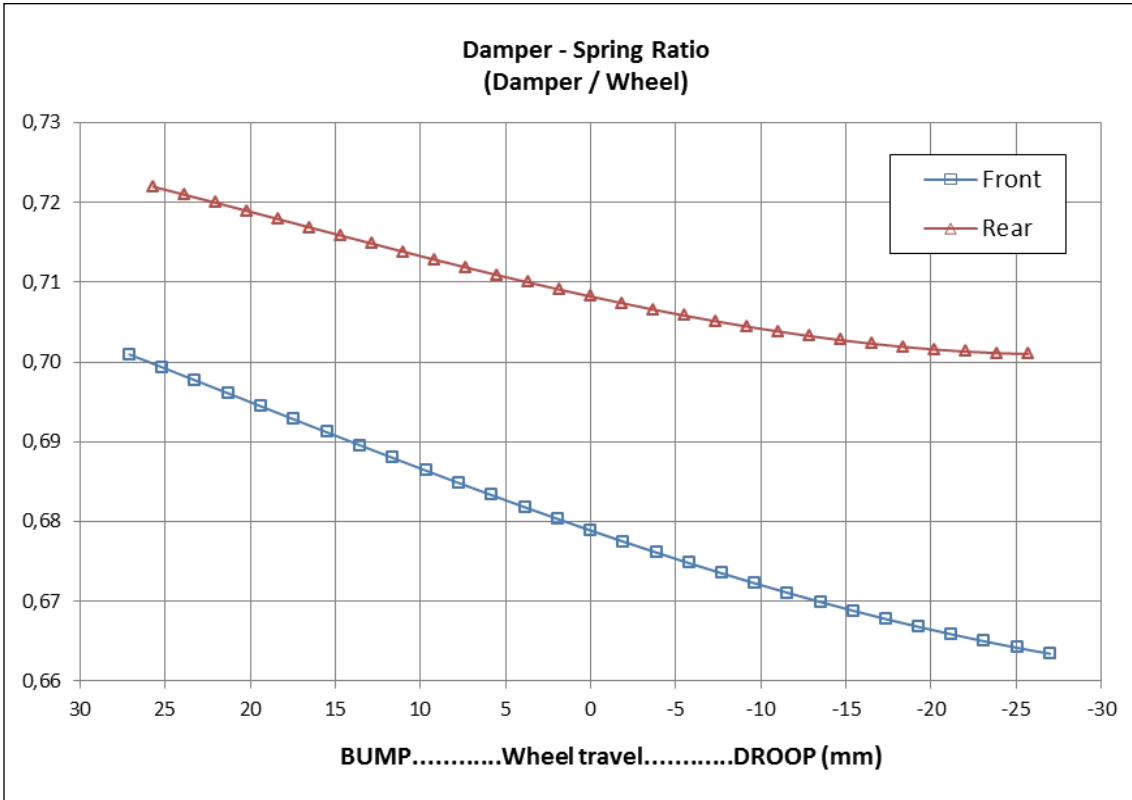

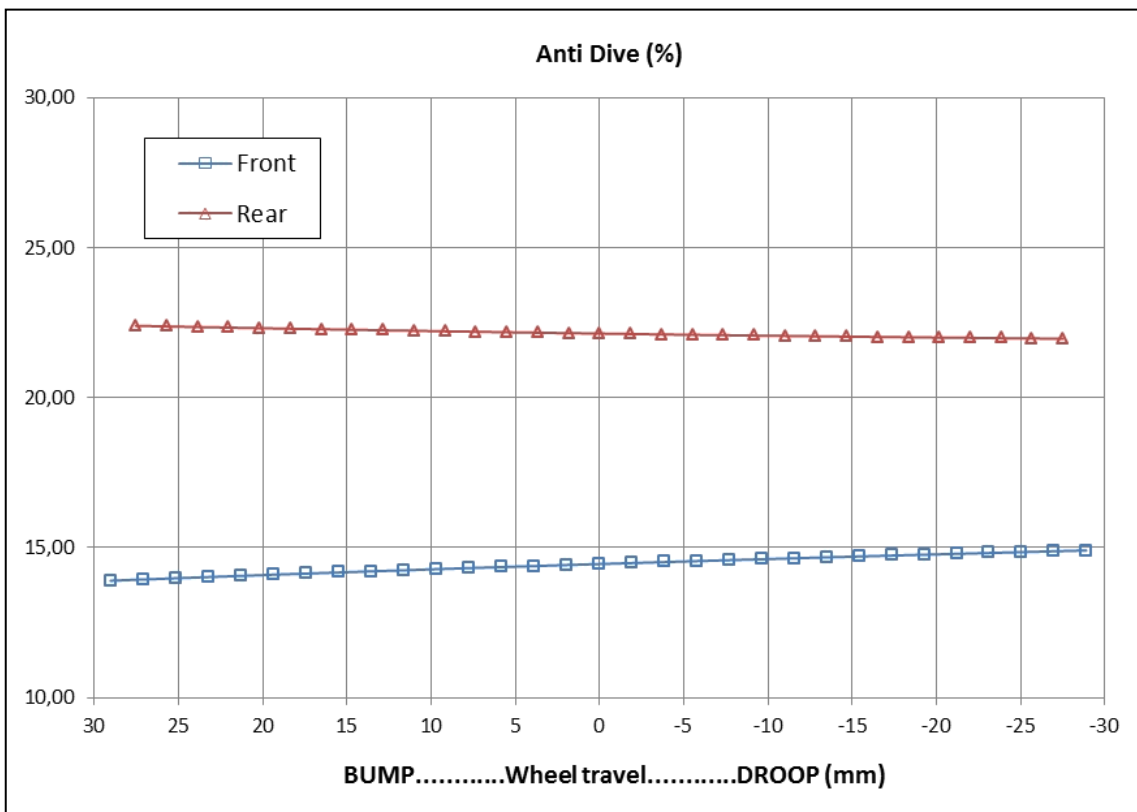
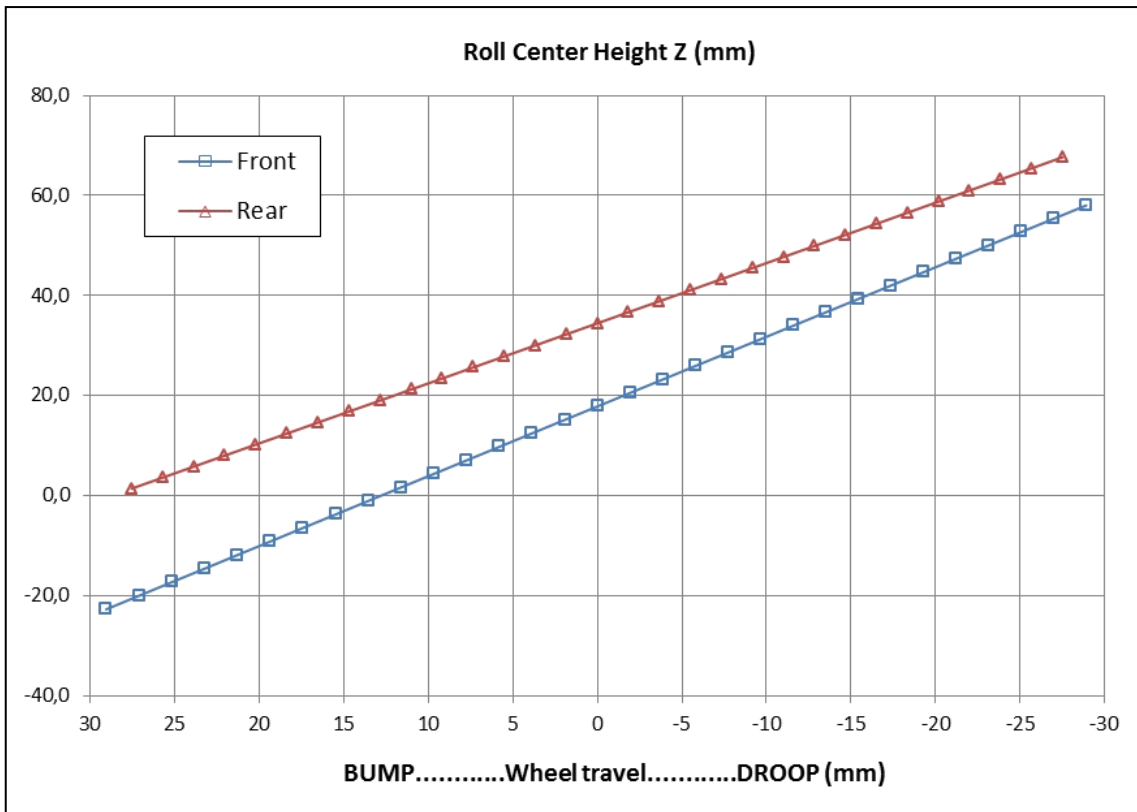

Motion ratio

$$\text{Motion ratio (MR)} = \frac{\text{Damper travel}}{\text{Wheel travel}}$$

$$\text{Wheel rate} = \text{Spring rate} * \text{MR}^2$$

In baseline position :

DAMPER FRONT	0.68
ROLL BAR FRONT	0.69
DAMPER REAR	0.71
ROLL BAR REAR	0.48

3.4 SPRINGS

Front and rear suspension springs are common sizes.

Part Number		F.41.14.022.A	F.41.14.024.A	F.41.14.026.A
Stiffness	lbs/inch	600	800	1000
Stiffness	N/mm	106	141	176

3. 5 DAMPERS

3.5. 1 FRONT SUSPENSION DAMPERS

The standard front damper is the Sachs F4 non-adjustable front damper, reference F.41.14.103.A.

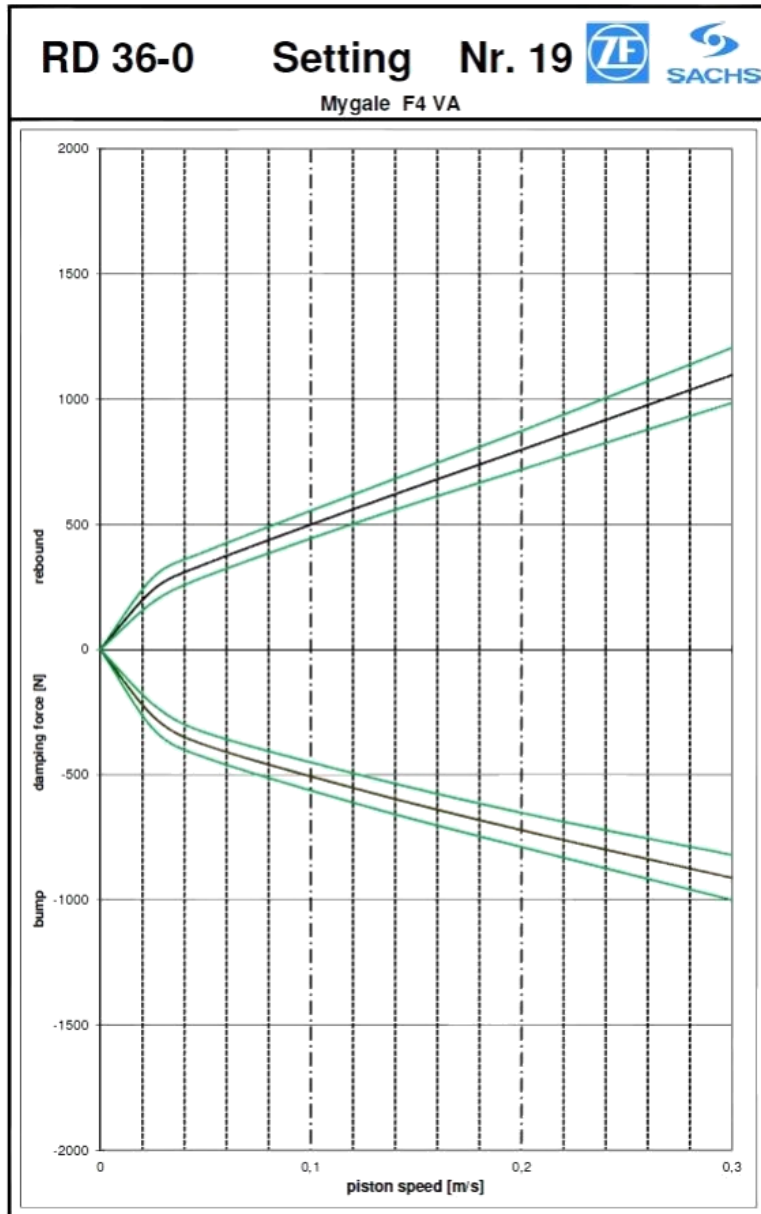

3.5. 2 REAR SUSPENSION DAMPERS

The standard rear damper is the Sachs F4 non-adjustable rear damper, reference F.41.14.029.A.

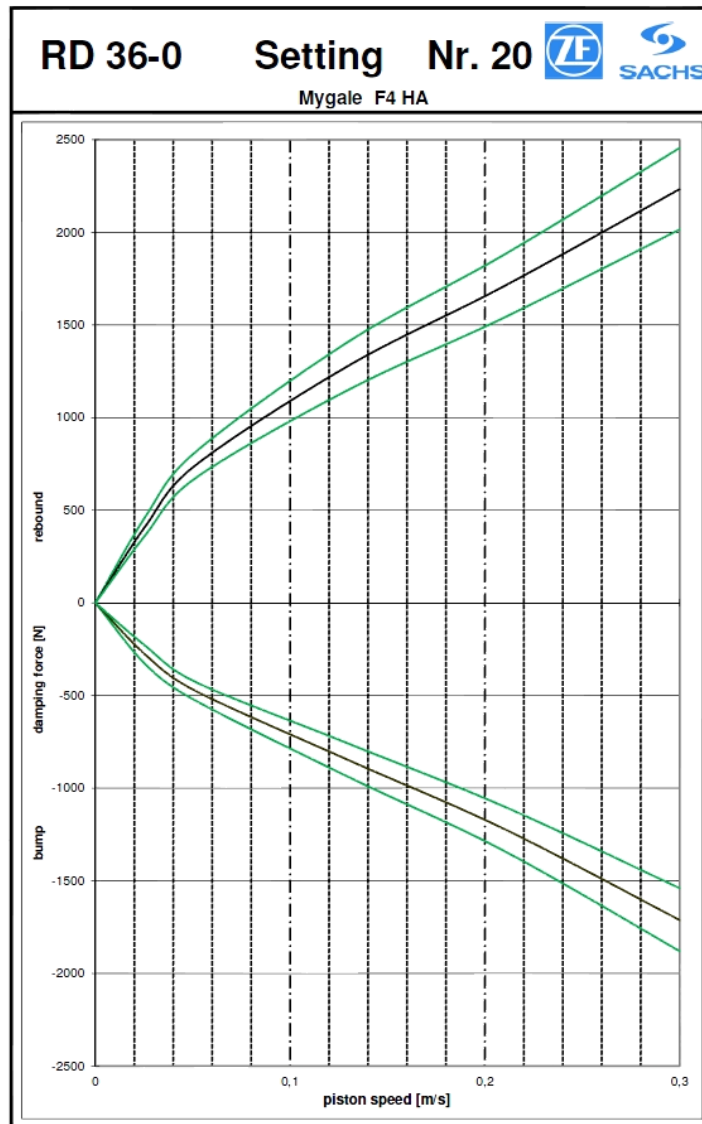

3.5. 3 ADJUSTABLE DAMPERS

2 ways Sachs adjustable dampers are available as an option.

3.6 ANTI- ROLL BARS

The front and rear anti-roll bars each have 5 adjustable positions. To adjust the anti-roll bar the retaining screw of the adjustment clevis must be unscrewed and the clevis moved up or down until the setting position is reached.

3.6. 1 ANTI- ROLL BARS ADJUSTMENT

Various stiffness of anti-roll bar are available. To eliminate pre-load in the anti-roll bar, the length of the adjuster assembly connecting the anti-roll bar to the rocker should be shortened or lengthened to suit.

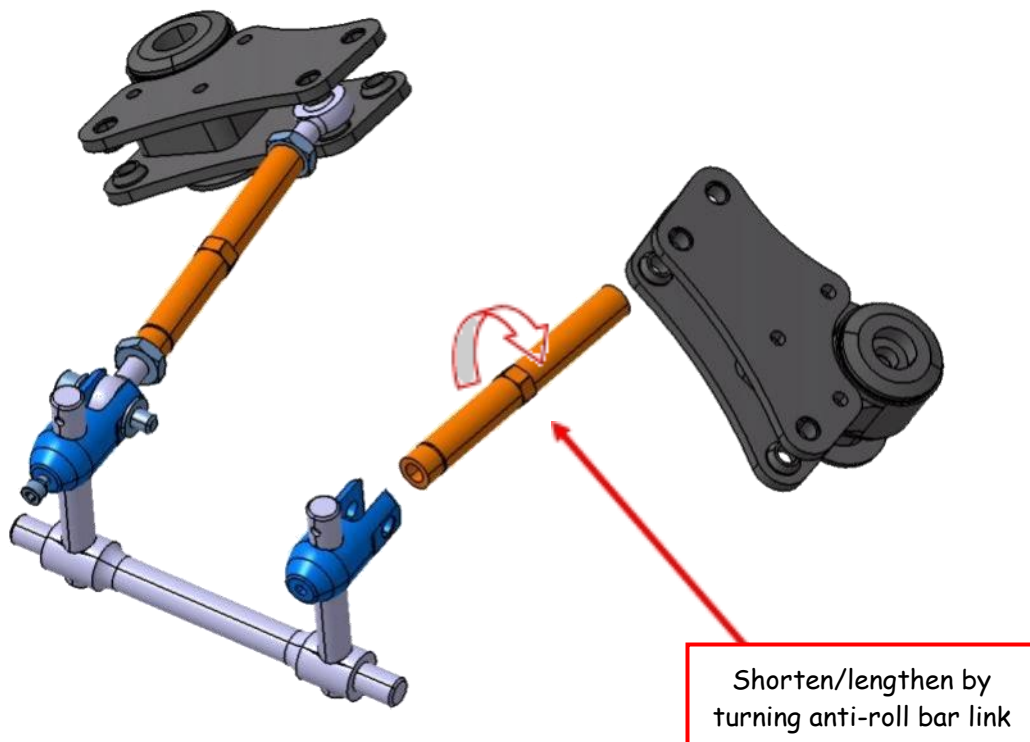

3.6. 2 ANTI- ROLL BAR STIFFNESS

ARB currently available
 Standard ARB : Ø14
 (Optionnals ARB : Ø12 and Ø18)

ARBØ	Position					N/mm
	1	2	3	4	5	
Ø12	221	311	411	571	765	N/mm
Ø14	352	501	681	928	1271	
Ø18	621	912	1257	1764	2504	

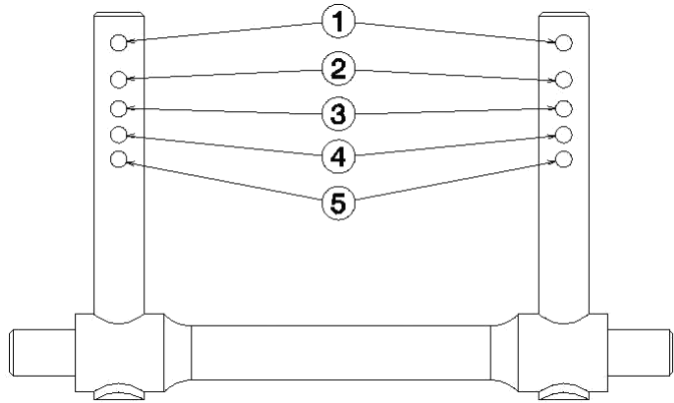

Here the anti-roll bar rate graph from the different anti-roll bar diameters and positions.

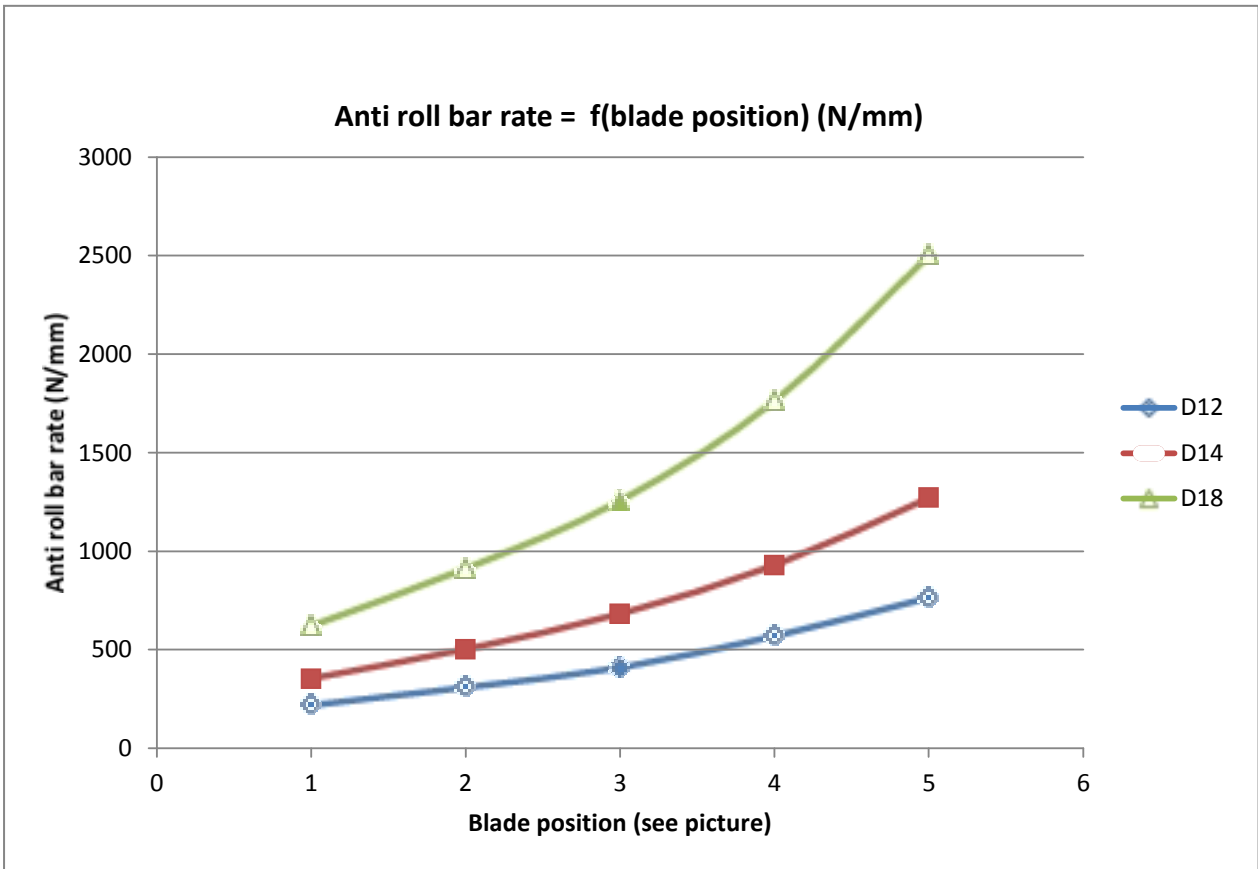

3.7 AERO SET UP

3.7.1 FRONT WING

Position Convention: Angle of the front wing main plate with the reference plane (red line):

	Front wing
Standard position	-3°
Range	-5°/+2°

Front wing set up:

- Set up the front wing main plate at the desired position
- Adjust the front wing end plate to be parallel to the reference plane

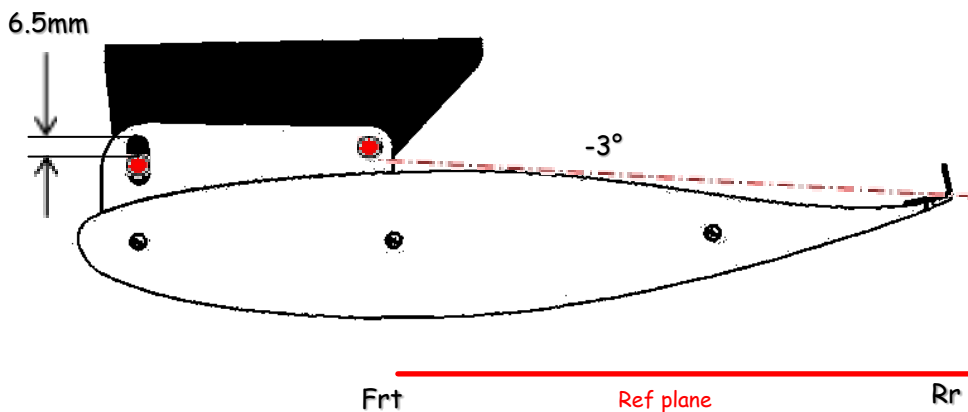

Evolution of downforce coefficient (SC_z), drag coefficient (SC_x) and balance with front wing main plane angle:

Delta wing angle	Delta SC_x	Delta SC_z	Delta balance
+1°	-	+0.06	+4.6%

Standard specification includes a gurney on the trailing edge on each lateral extremity of the wing (part number F.41.24.009.A).

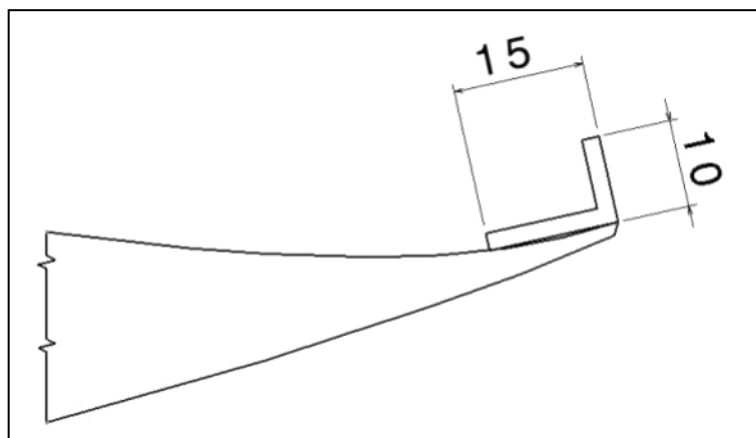

3.7. 2 REAR WING

Position Convention: Angle of the wing main plate with the reference plane (red line):

	Upper wing	Lower wing
Standard position	+5°	0°
Range	0°/+15°	0°/+4°

Rear wing set up:

- Set up the lower wing at the desired position
- Adjust the rear wing end plate to be parallel to the reference plane
- Set up the upper wing at the desired position by using the adjusting holes

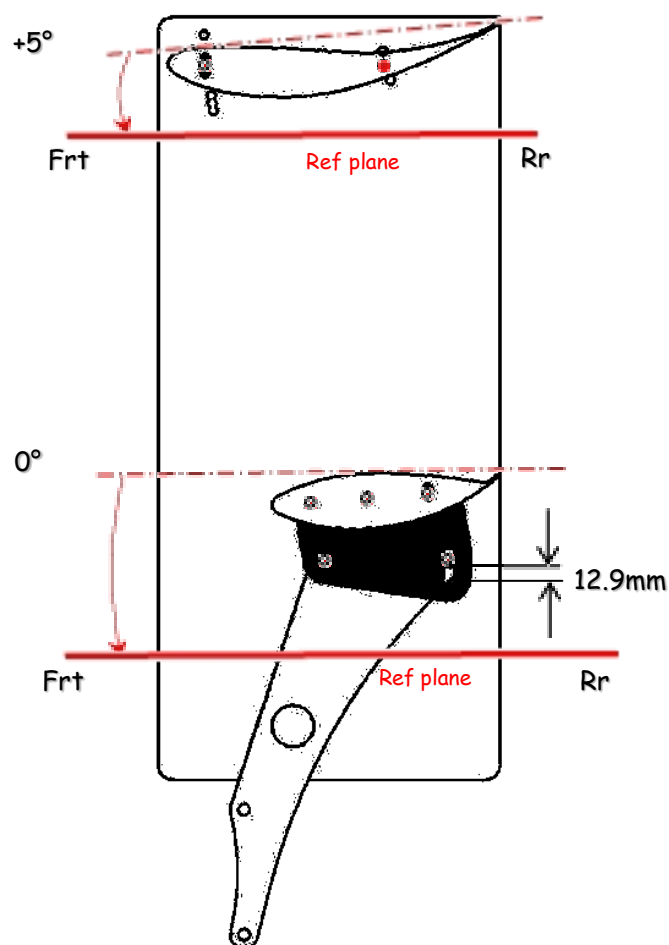

Details on the rear upper wing positions:

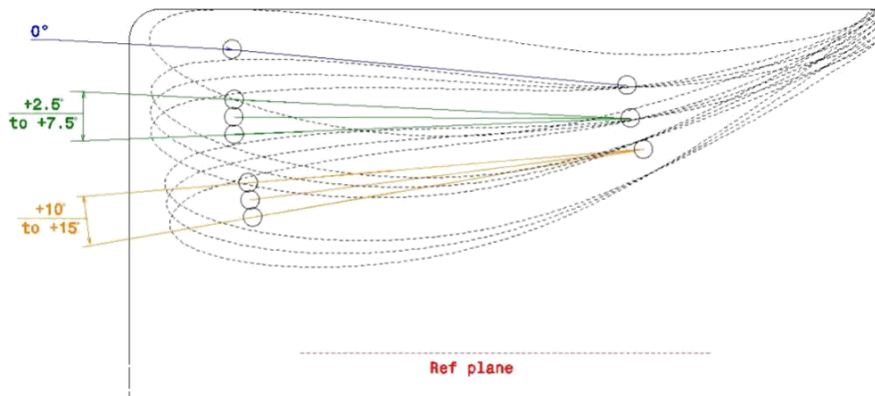

Evolution of downforce coefficient (SC_z), drag coefficient (SC_x) and balance with rear wing angles:

	Delta wing angle	Delta SC_x	Delta SC_z	Delta balance
Upper wing	+2.5°	+0.006	+0.034	-2.5%
Lower wing	+1°	+0.001	+0.011	-0.8%

3.8 BRAKE BIAS

Range: 17.5 turns

Adjustment: more front brake = turn left

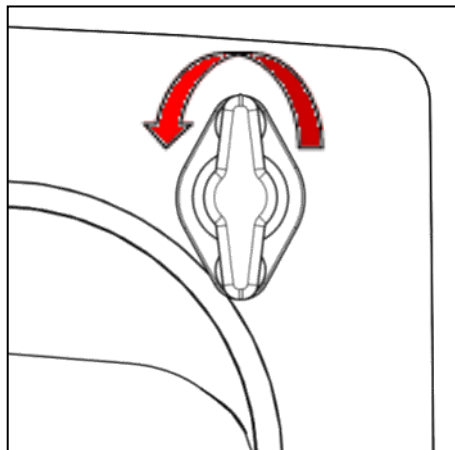

A spacer is available as optional part for the brake bias control:

- F.41.11.057.A: Length 100mm

Teams are allowed to adjust its length to optimize driver comfort.

3.9 PEDAL BOX ADJUSTMENT

According to the driver feeling, the width of the brake pedal can be adjusted by the team. It is possible to cut the shaded area below:

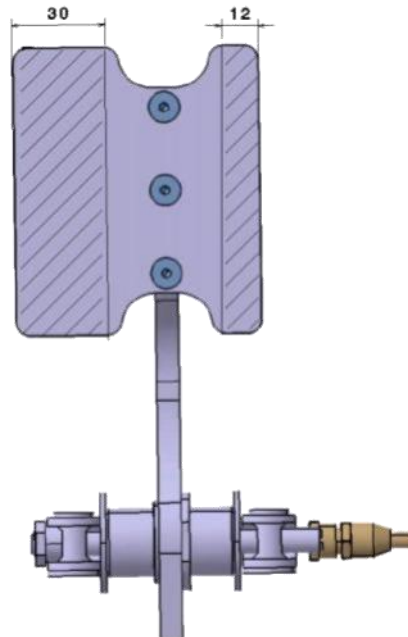

For ergonomic reasons, 5 Pedal Box's positions are available:

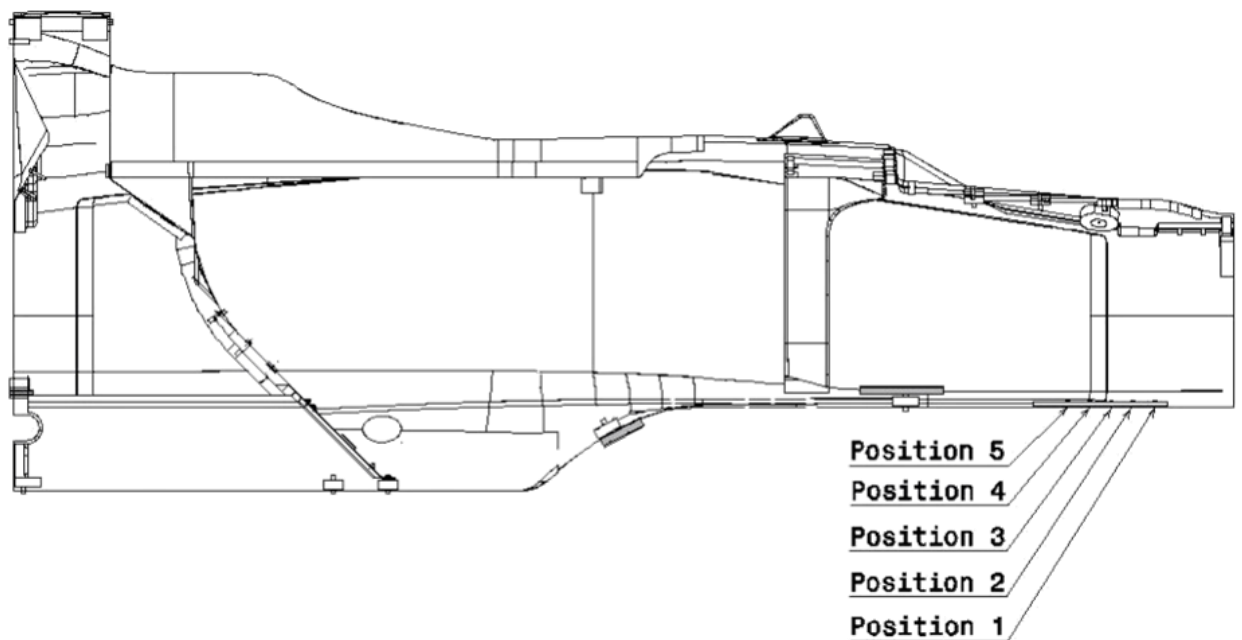

Each position has an equipment which is available in option.

Position 1 :

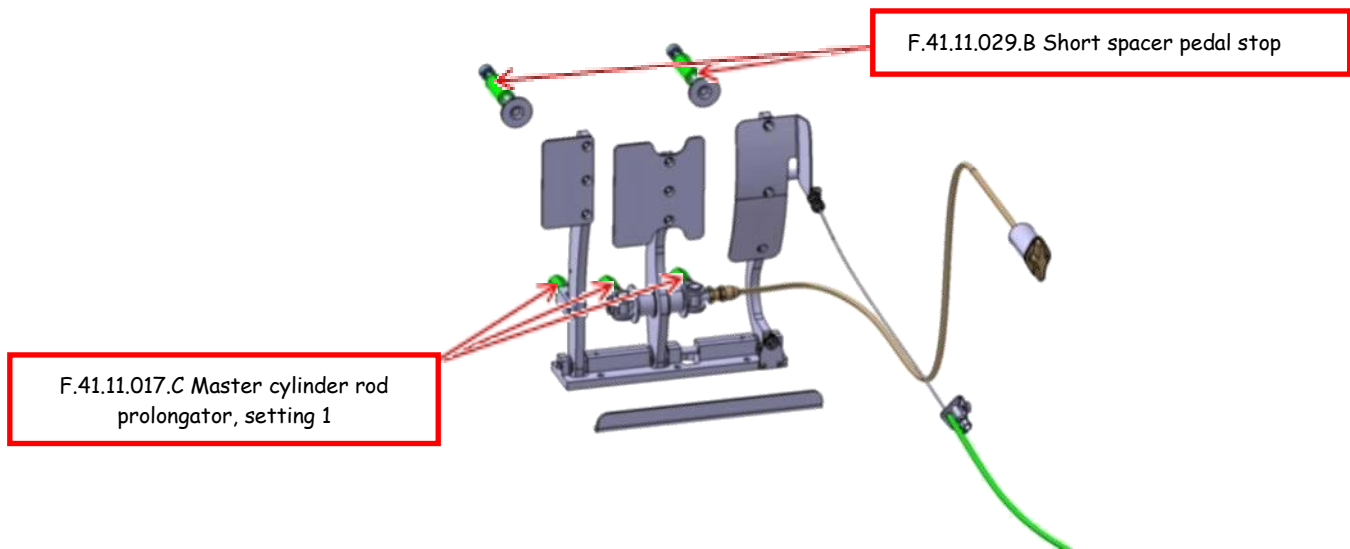

Position 2 :

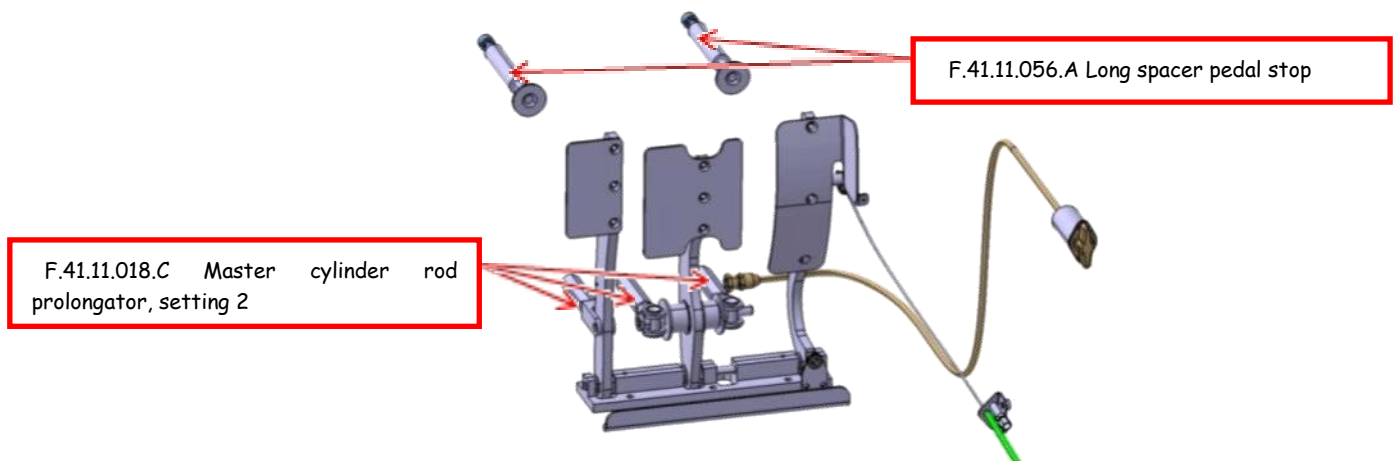

Position 3 :

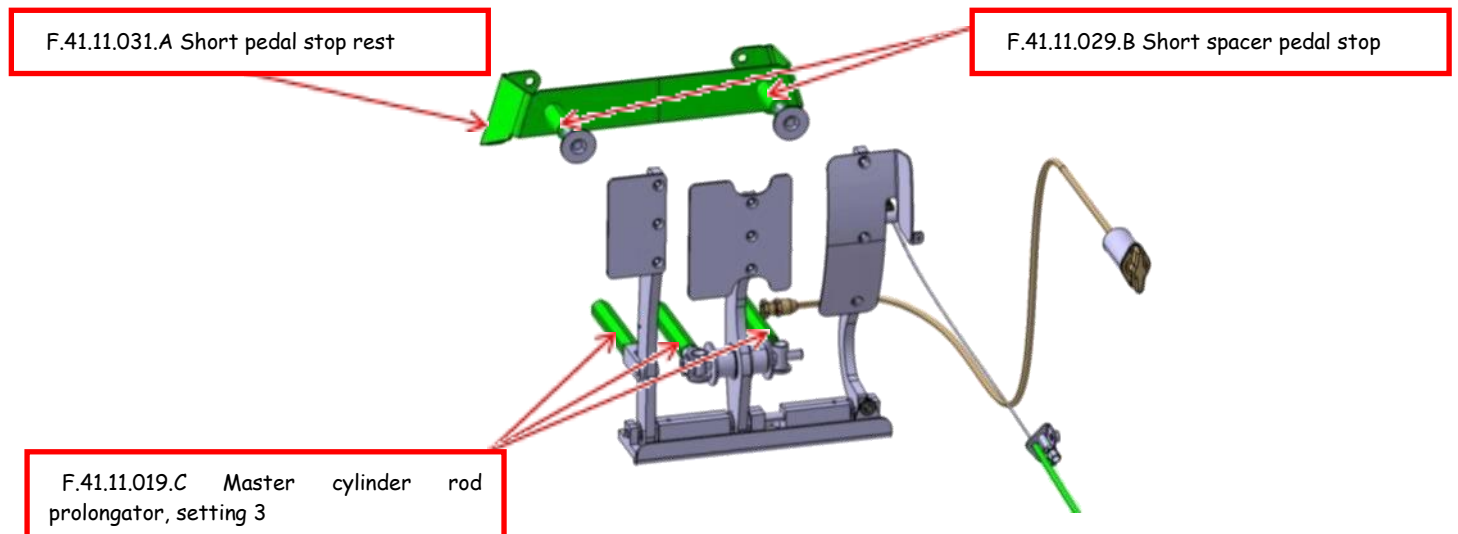

Position 4 :

F.41.11.031.A Short pedal stop rest

F.41.11.056.A Long spacer pedal stop

F.41.11.020.C Master cylinder rod
prolongator setting 4

Position 5 :

F.41.11.032.A Long pedal stop rest

F.41.11.056.A Long spacer pedal stop

F.41.11.021.C Master cylinder rod
prolongator, setting 5

The throttle cable must be cut at the right length once the pedal box is correctly positioned for the driver.

For small drivers, it is also possible to offset the pedal box more rearward, with a maximum of 450mm between brake pedal plate and front end of the monocoque. The following picture shows the maximum rearward position of the pedal box:

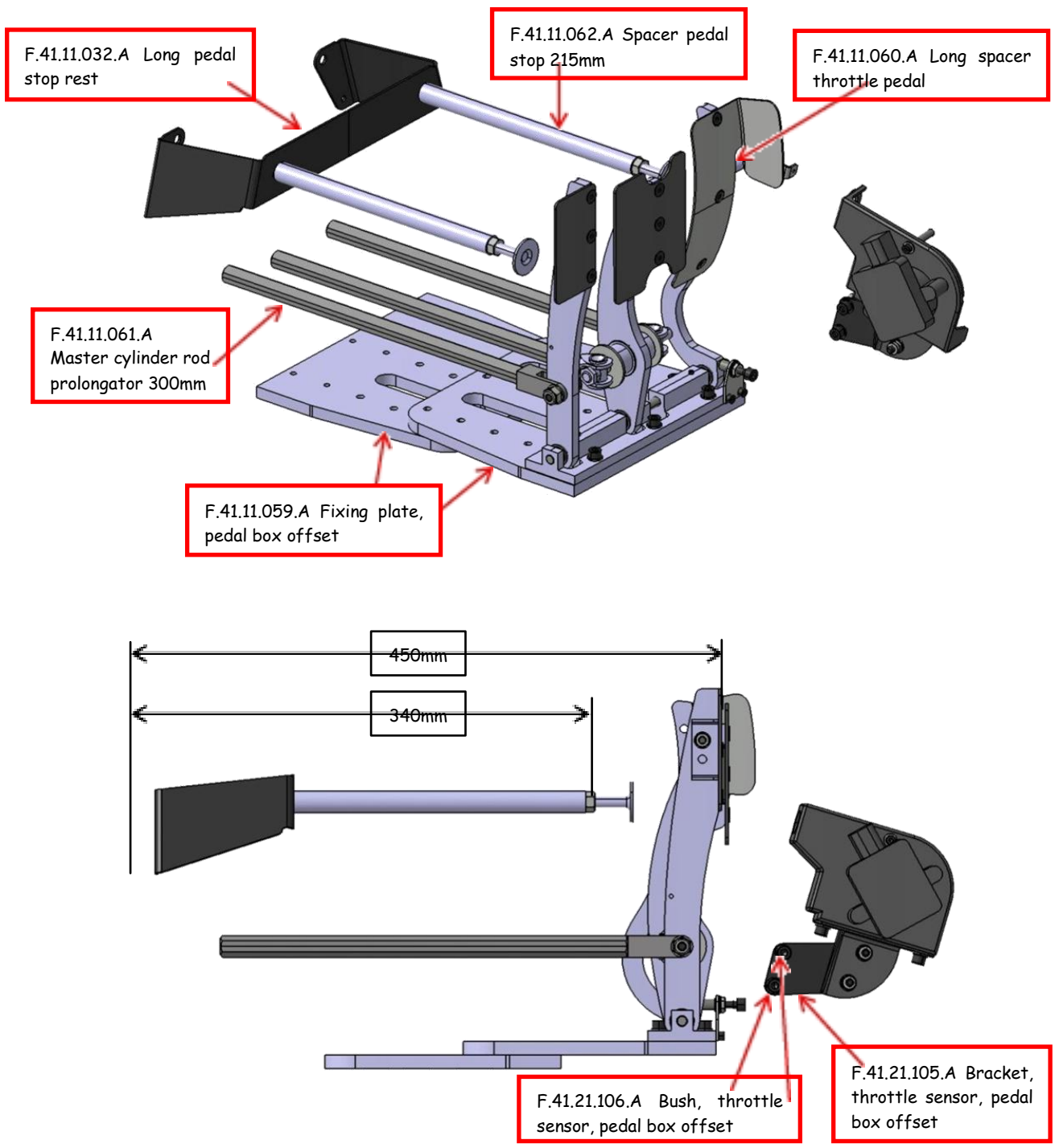

3.1 0 SET- UP SHEET BASELINE PROPOSAL

SET-UP SHEET M14-F4

Car
Date
Circuit
Run

		FRONT				LH
		LH		RH		LH
Weight						
Included / not included						
Per wheel	Kg					
Total	Kg					
Weight distribution	%					
Ride height	mm		19		30	
Geometry						
Camber	°	3,3	3,3	2,2	2,2	
Camber shims	mm					
Toe per wheel (in+/out-)	mm	1	1	1	1	
Castor	°	8.2	8.2	-22.8	-22.8	
Wheelbase	mm	2742				
Width	mm	1725		1715		
Suspensions						
Dampers						
Type		Sachs non adjustable		Sachs non adjustable		
Bump	pos					
Rebound	pos					
Springs						
Stiffness	lbs/in	800	800	800	800	
Preload	mm	4.7	4.7	0	0	
Anti-roll bar						
Diameter	mm	14		14		
Blade set-up	mm	3	3	3	3	
Tyres						
Type						
Pressure - cold	bar					
Pressure - hot	bar					
Brakes						
Master cylinder		0,625		0,75		
Balance	%					
Pads		DS PERFO	DS PERFO	DS PERFO	DS PERFO	
Wings						
Angle (- nose up/+ nose down)	°	-3		5 (top) / 0 (beam)		
Gurney		10x345				
Clutch						
Master cylinder		0.75				
Gearbox						
Crownwheel & pinion		10/31				
1st		14/37				
2nd		18/35				
3rd		18/28				
4th		21/27				
5th		20/22				
6th		27/26				
Cooling						
Radiator blanking	%					

Comments

3.1 1 BALLAST

Ballast is used to reach the minimum allowable weight

Two ballast fixing locations are provided: inside the splitter and in the cockpit under driver's legs (bottom view of monocoque).

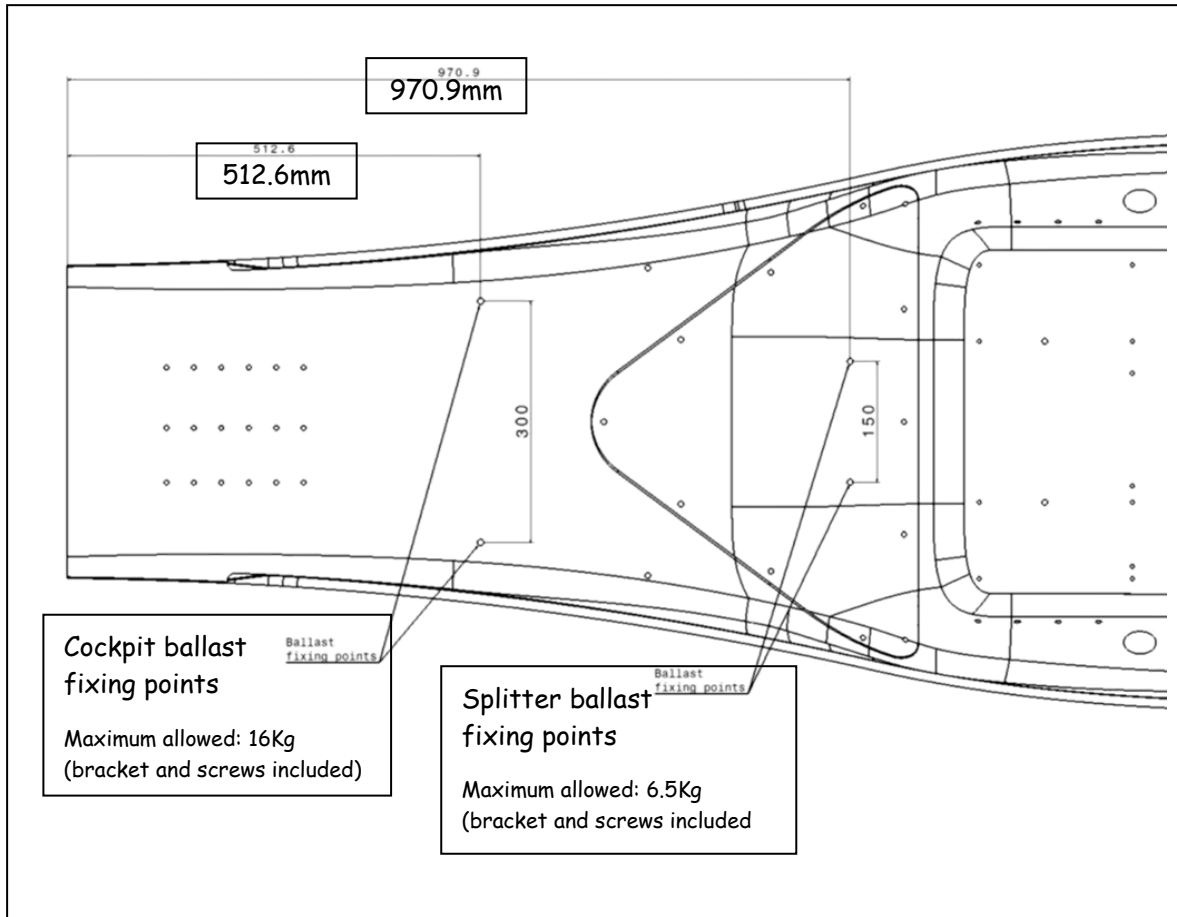

Standard ballasts:

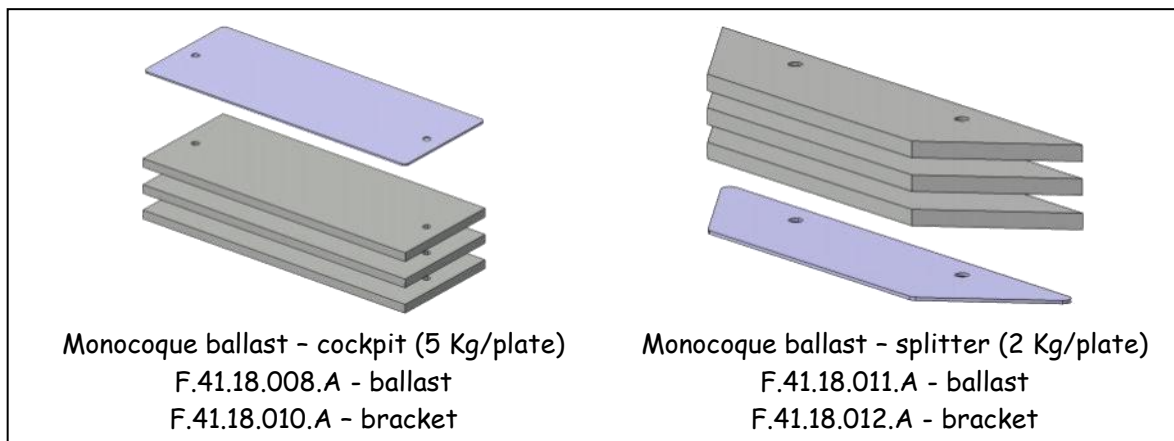

3.1 2 PADDLE SHIFT

An optional kit with a paddle shift system is available to replace the manual shifting system. It includes the GCU, the pneumatic actuator and controller, the steering wheel with shift controllers and the display.

3.1 2. 1 PADDLE SHIFT USER MANUAL

- To engage 1st gear (when neutral "N" is displayed on the dashboard) push Neutral (N) together with shift paddle "UP".



- To return to neutral (when 1st gear "1" is displayed on the dashboard) push Neutral (N) together with shift paddle "DOWN".



- To shift into reverse (when neutral "N" is displayed on the dashboard) push Neutral (N) together with shift paddle "DOWN".



3.1 2. 2 GEAR- SHIFT PNEUMATIC JACK

Rod position on gear-shift pneumatic jack may have to be adjusted:

Due to parts manufacturing tolerances, to have the right rod position setting to avoid gear-shift issue, you may have to adjust following distance from 26.5 to 25 mm

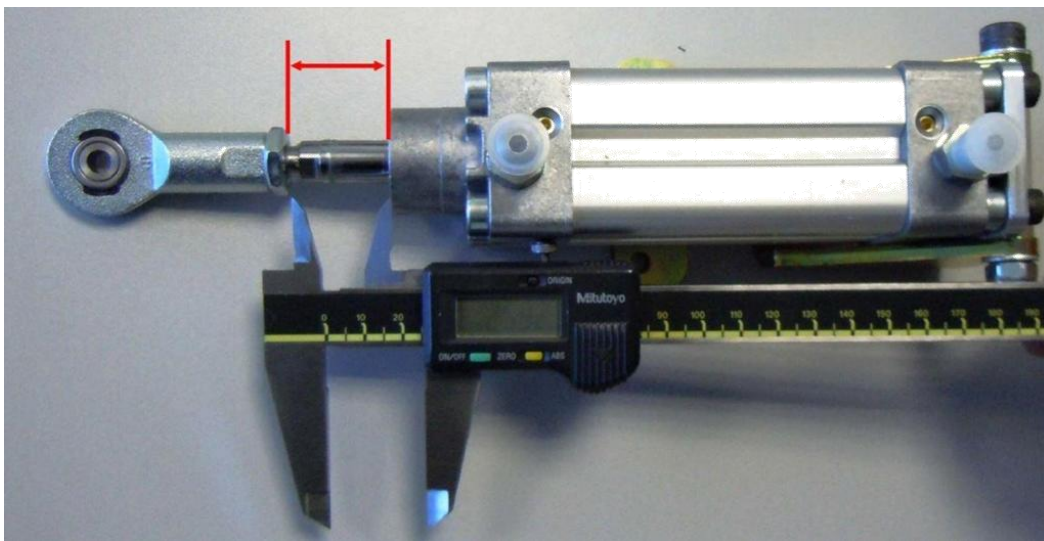

3.1 3 GEAR BOX RATIOS

The standard gearbox build specification is:

Differential: free (open with no limited slip)

CWP ratio: 10/31

Gear ratios: 1st 14/37

2nd 18/35

3rd 18/28

4th 21/27

5th 20/22

6th 27/26

The gear ratios are drawn on the following graph:

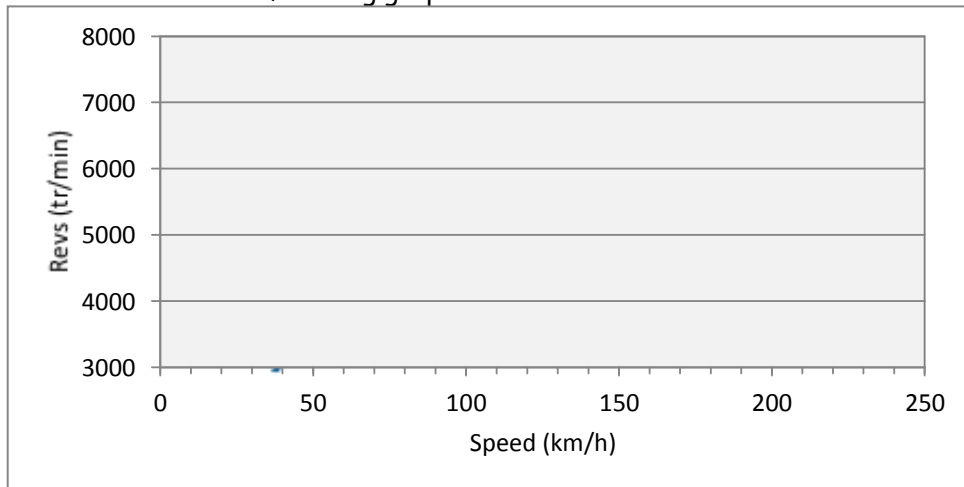

Shot gear ratios are available in option:

Gear ratios (option):

4th 22/29

5th 24/28

6th 22/23

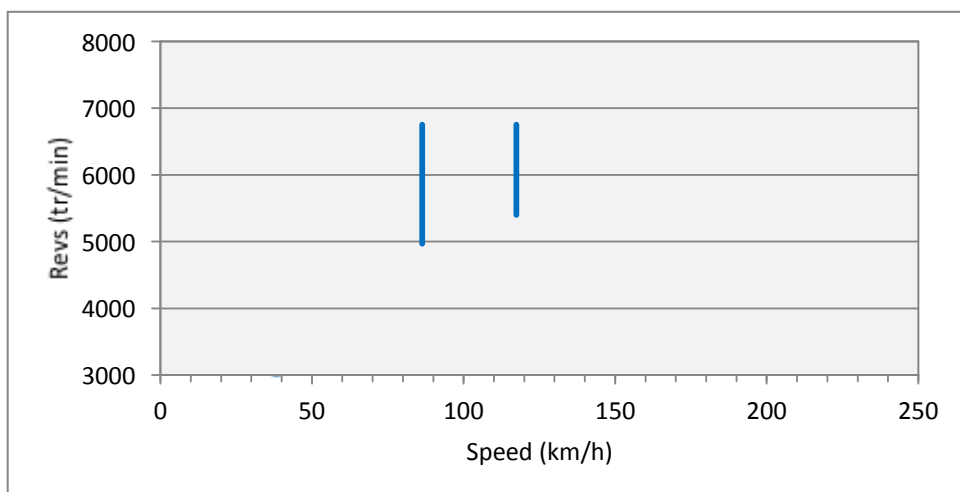

3.1 4 DATA ACQUISITION

The following sensors are included in the data acquisition optional kit:

- Steering angle
- Front wheels speed
- Acceleration in 3 axes
- Front and rear brake pressure
- Lap timer
- Gear
- Throttle pedal
- Smarty camera

Front and rear, right and left dampers travel sensors are available in option, for testing only (forbidden in F4 technical regulation).

3.1 5 BRAKE PADS

The standard fit brake pads are the Ferrodo DS performance, reference F.41.17.004.A are identical front and rear.

Other brake pads are available in option:

- Ferrodo DS3000 (reference F.41.17.007.A).
- Ferrodo DS1.11 (reference F.41.17.008.A).

New brake pads must always be bedded following Ferrodo bedding recommendation. Heating gradually stepwise, until minimum 500°C is reach.

3.1 6 STEERING SYSTEM ADJUSTMENTS

The height of the steering column can be adjusted by changing the position of the bracket on the monocoque.

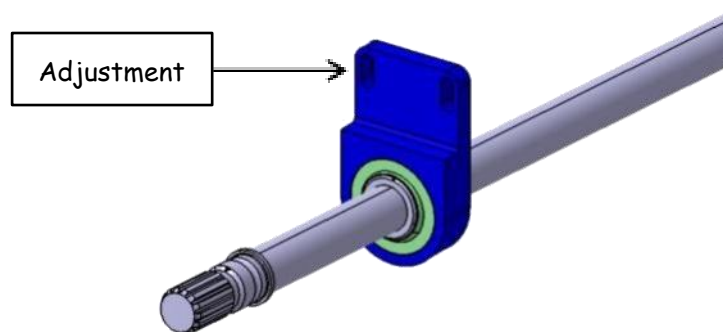

In addition to the standard steering column, a longer steering column is available as optional part:

- F.41.16.001.B: Standard length
- F.41.16.046.A: Length +80mm

Spacers for the steering wheel are also available as optional parts to adjust the longitudinal position of the steering wheel (reference F.41.16.003.B).

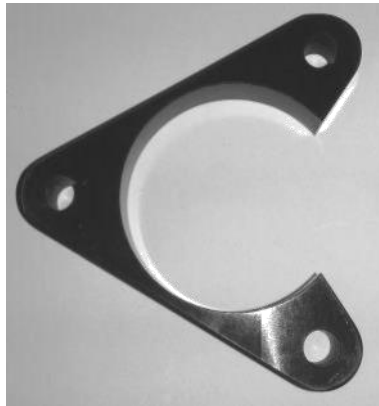

It is also possible to cut the steering rack stop to adjust maximum steering angle:

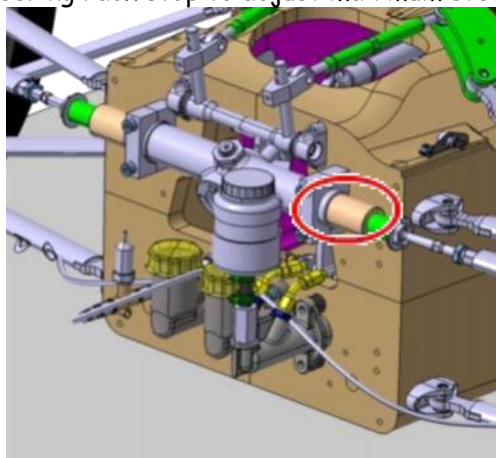

3.1 7 RADIATOR PROTECTION GRILLE

Radiator grille protections are available as optional parts (ref. F.41.26.081.A):

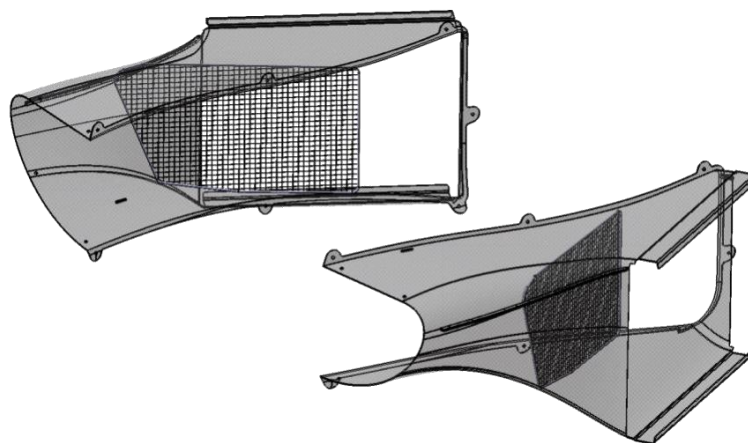

4.0 ASSEMBLY AND MAINTENANCE

Note: all safety critical components should be checked regularly.

4.1 ENGINE

4.1 . 1 OVERVIEW

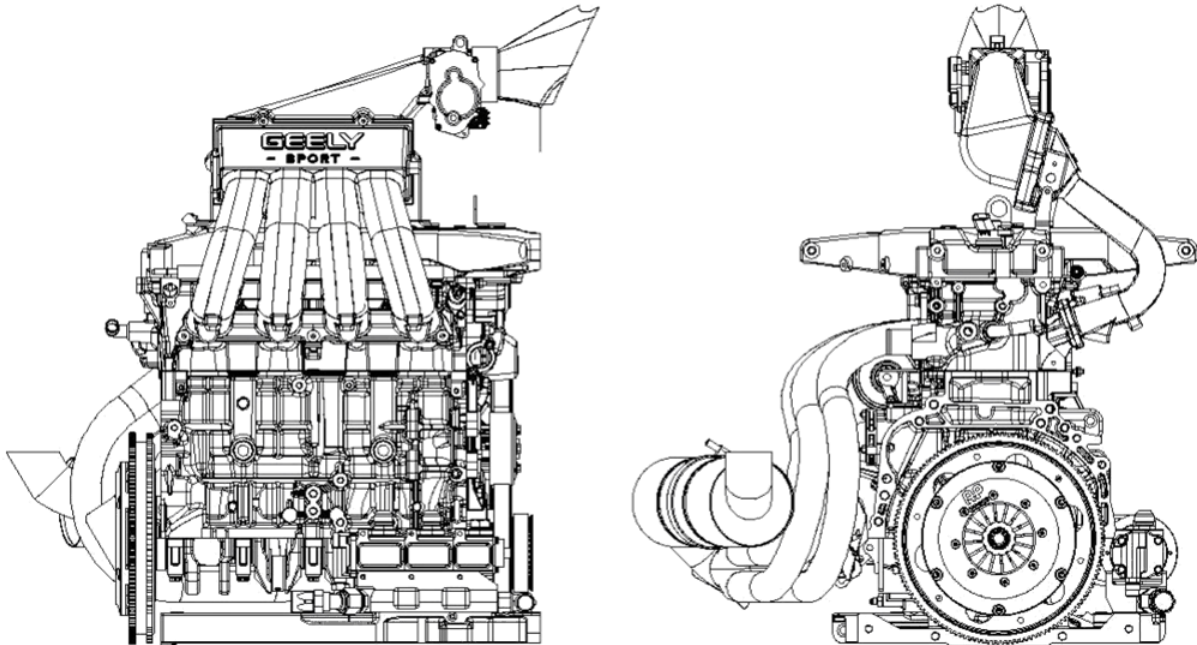

4.1 . 2 ENGINE OPERATING CONDITIONS

$72^{\circ}\text{C} < \text{Water } T^{\circ} < 85^{\circ}\text{C}$

$80^{\circ}\text{C} < \text{Oil } T^{\circ} < 120^{\circ}\text{C}$

-> Warm up the engine before driving (Engine temperature 80°C)

Poil min = 1.2 bar

Rev. limits: 6750 rpm

Refer to the engine user manual for all other information.

4.2 TRANSMISSION

4.2. 1 GEAR BOX

The Sadev SL75-14 LW F4 gearbox is homologated for use in the Mygale M14-F4. No other gearboxes have passed a rear impact crash test.

Clutch shaft specification depends on the gearbox manufacturer and the type of engine.

For all information regarding build and maintenance gearbox, customers should refer to the Sadev user manuals.

4.2. 2 DRIVE SHAFT

The standard fit driveshaft is supplied by Sadev.

For safety reasons, right and left driveshafts must not be inverted.

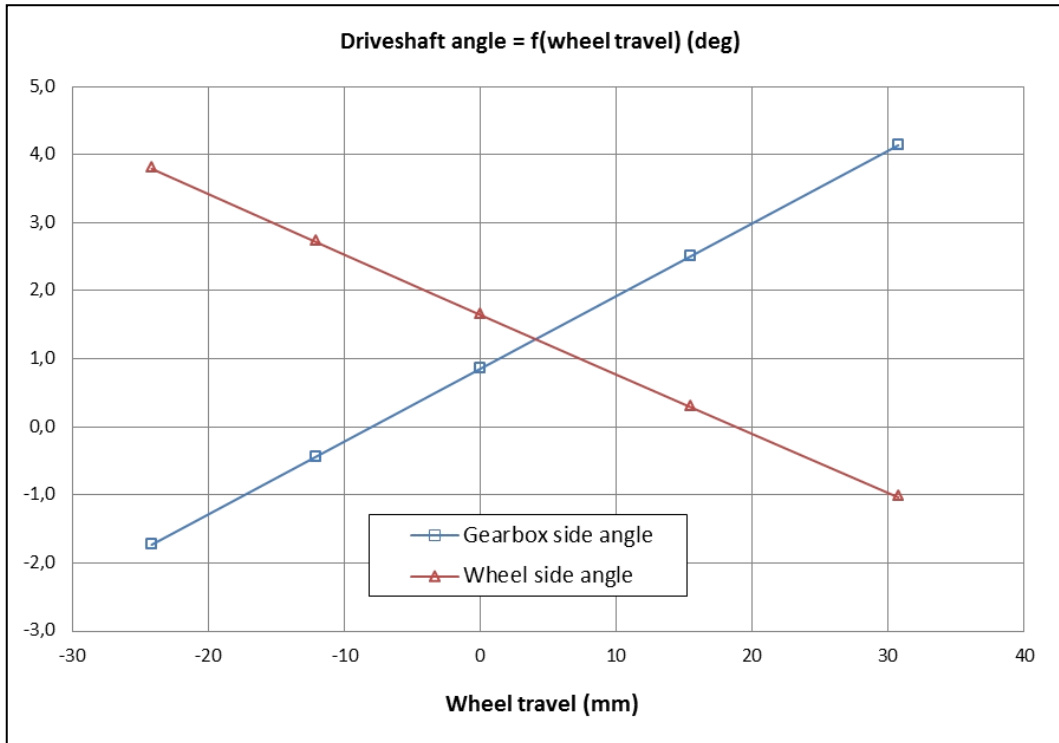

Driveshaft angles are given for 2.5° negative camber, face viewed.

It appeared that under certain circumstances, driveshaft CV boots diameter can expand too much with centrifugal forces and be damaged rubbing the pushrod. It is recommended to use lockwire inside each groove of the boot, as per photo below, in order to contain its expansion and avoid any damage.



4.3 STEERING SYSTEM

The steering rack and steering column are homologated components which may not be modified.

4.3.1 STEERING RACK

Tightening torque to ensure the steering rack movement: 34Nm

4.3.2 STEERING COLUMN

The steering column includes a collapsible device homologated with the FIA which must not be modified. The column length must not be altered by adjustment of the length of the collapsible device.

The upper and lower parts of the column are joined by a splined sliding section, held together axially by a capscrew which tightens against the collapsible device. If disassembled, must be reassembled with grease.

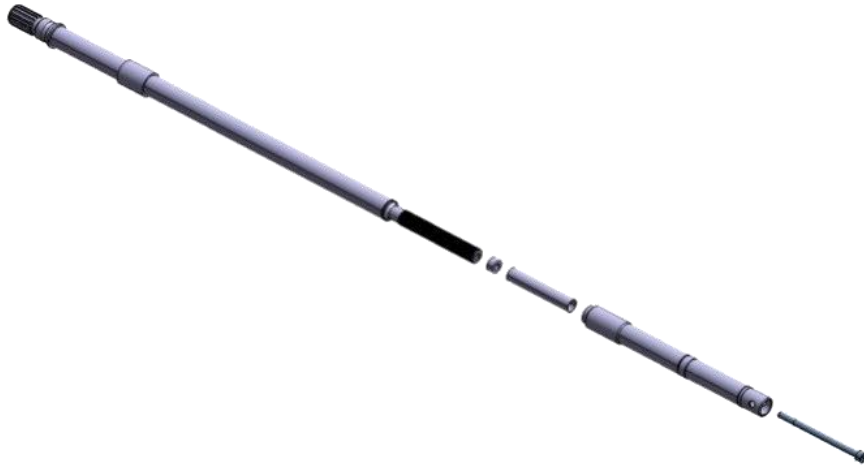

Section of the steering column assembly:

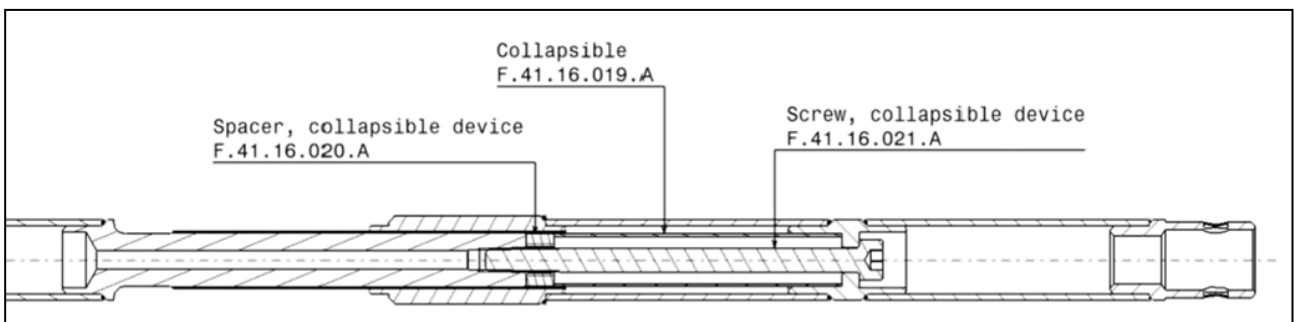

4.3. 3 STEERING COLUMN JOINT

For safety reasons, it is recommended to thoroughly inspect the steering column joint after each shock or crash.

4.3. 4 STEERING WHEEL GLASS

When removing the steering wheel some drivers or mechanics may push the glass with their fingers. Be careful, pushing too hard could break the sealing and cause glass damage.



4.4 HUB ASSEMBLY

4.4.1 FRONT AND REAR HUB ASSEMBLY

The uprights, wheel bearings, wheel drive pegs and lock nuts are identical front and rear.

- At the front the front stud is fitted in the wheel bearing.
- At the rear the driveshaft is fitted directly in the wheel bearing.

It is not recommended to engage the wheel nuts with a pneumatic screwdriver.

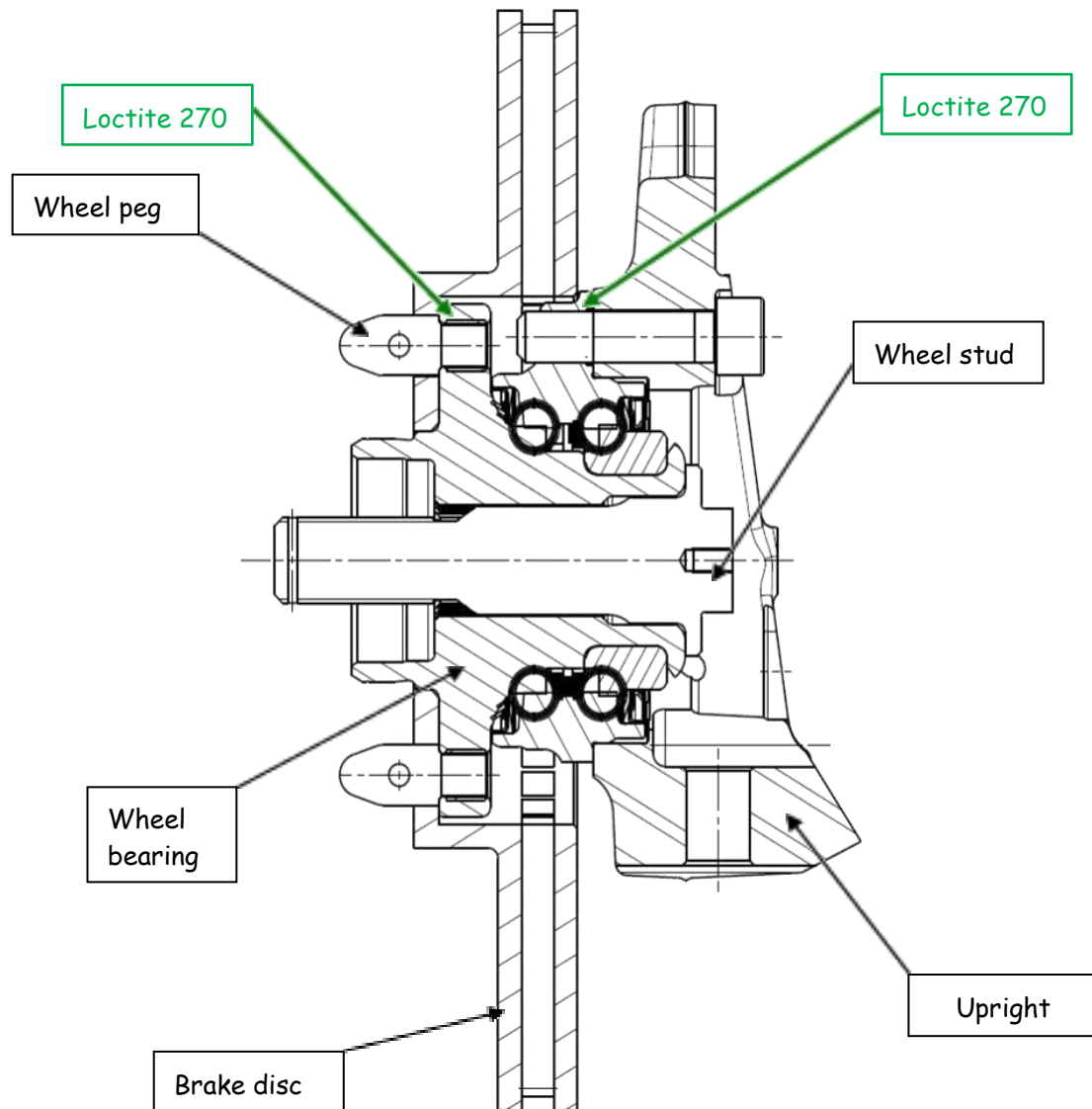

4.4. 2 WHEEL SPEED SENSOR

Provision for wheel speed sensors is made on the front uprights (data acquisition kit). The speed sensor bracket and disc are respectively references F.41.21.003.B and F.41.21.004.A. The spacer ref is F.41.21.079.A.

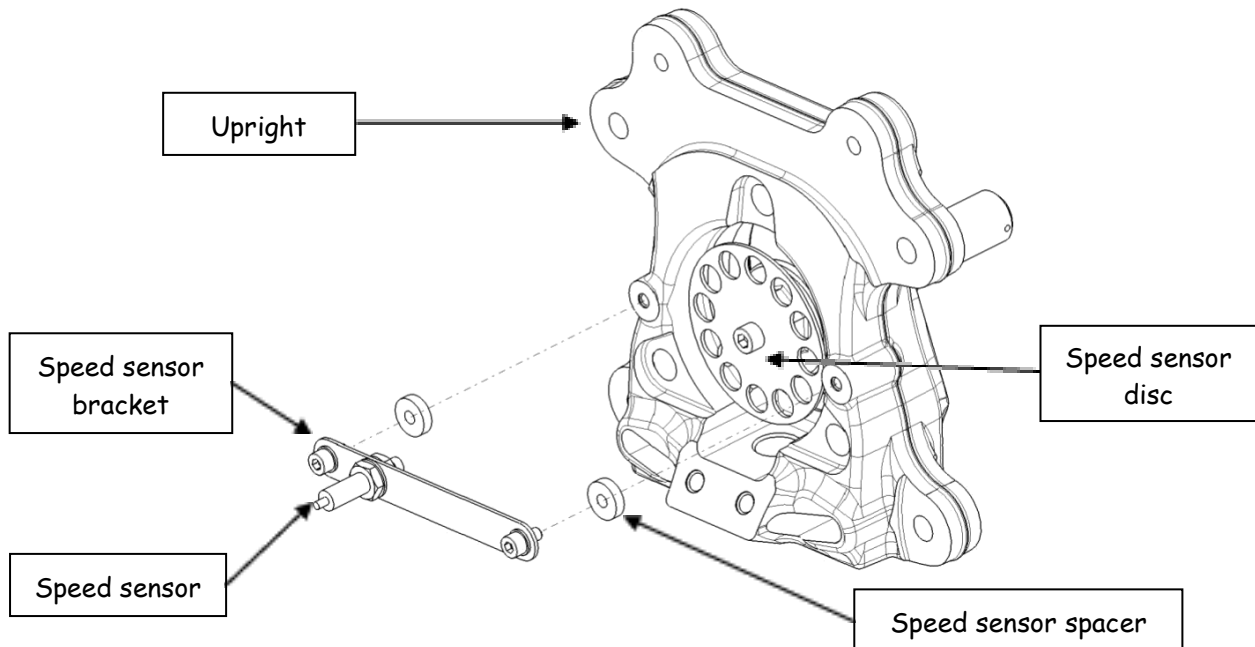

4.5 WISHBONES

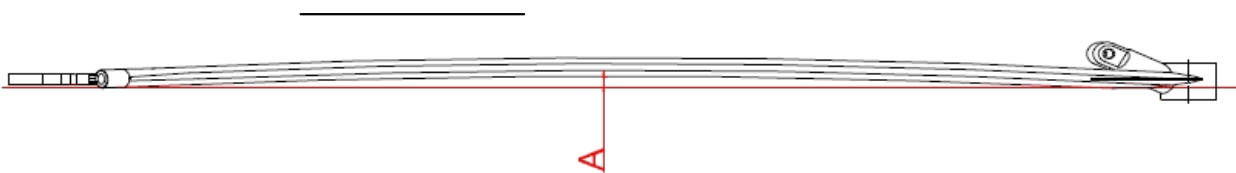

In the case of a damaged ball, Mygale proposes a staking bearing joint replacement (F.41.14.121.A).

Wishbone primary ball joint is glued with Loctite in its housing, and must be heated for disassembling.

4.6 WHEEL CABLES

It is recommended to replace cables if one or more of the following conditions is met:

- The cable has been on the car for 12 months
- The car has been in an accident
- The cable has been damaged, i.e. the braid, tape or mould have been damaged exposing the fibre
- The cable or cover has been cut out

4.7 HEAT PROTECTION

To avoid any damage to the composite bodywork, it is recommended to install a thermal protection on the floor, the sidepod and the engine cover around the exhaust.

Thermal protection is also recommended between the monocoque and the engine.

4.8 BRAKE LINE PROTECTION

To ensure a good protection for the brake line, it is recommended to replace the heat shrink sheath covering in the area of the wishbone when it is damaged.

4.9 ELECTRICITY

4.9.1 BATTERY

To ensure a good life time for the battery, it is recommended to charge it at the reception of the car and to charge it every 6 month when you don't use it.

4.9.2 COCKPIT SWITCH PLATE

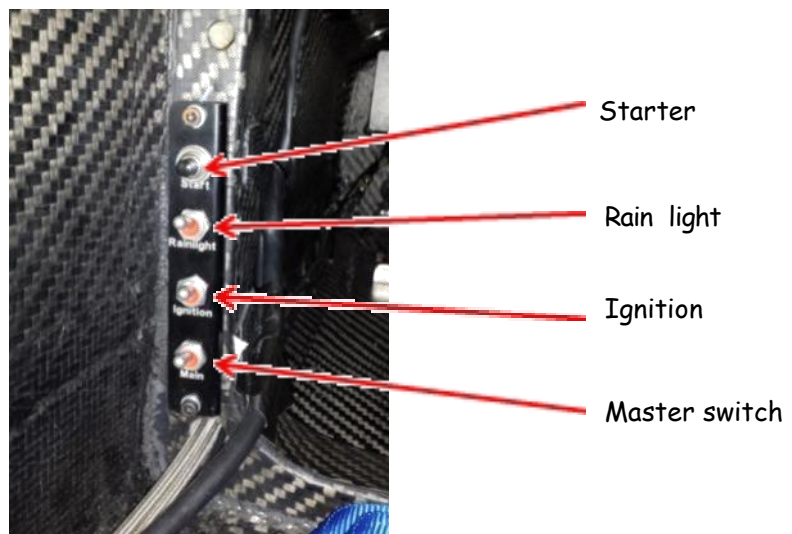

Spacers F.41.21.104.A are available as optional parts to offset the switch plate of 70mm. Teams are also allowed to reduced their lengths to optimize driver comfort

4.10 WINGS

For reliability reasons, it is highly recommended to replace the wings every two years. Moreover, it is also recommended to check the wings regularly in order to detect the potentially damaging effects of small hits or contacts on the endplates.

To avoid matting or weaken the front wing mounts, it is recommended to tighten them moderately on the crashbox, and to use the medium washer specified in the parts catalogue.

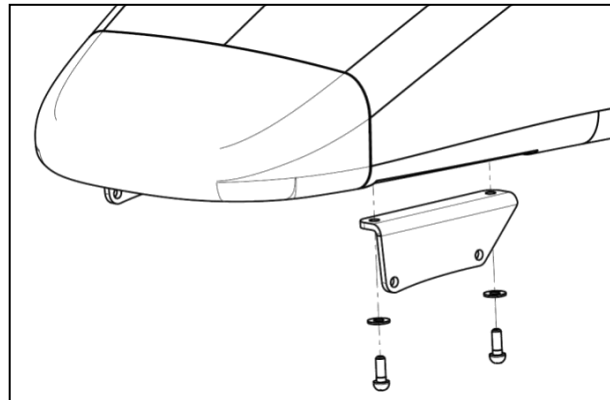

4.1 1 HEAD RESTRAINT

The head restraint must be properly assembled, with the fixations clipped securely. The head restraint must never be able to move freely.

According to the regulations, it is not permitted to cover the head restraint with any material other than paint.

In the case of a damaged Head Restraint, the aramid skin replacement by Mygale is available (ref.: F.41.19.060.A).

4.1 2 MONOCOQUE CHASSIS AND CRASH BOXES

Monocoque and crash box reparations must be performed by an approved entity. Before any modification or reparation, you **must** contact Mygale.

However, the team is allowed to change the nose cap. The nose cap must be properly assembled, with the fixations clipped securely on the main part of the crash box. Moreover, it is important to stick the nose cap on the crash box with four silicone points.

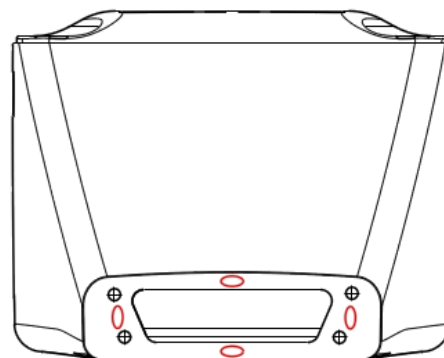
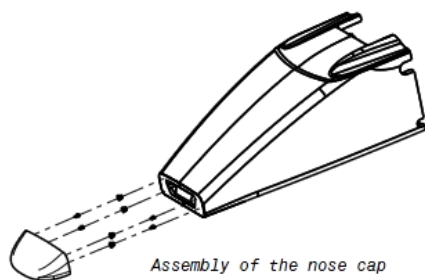

4 points of Silicone glue

4.1 3 BODYWORK REPAIRS

Teams are allowed to repair fibre glass bodywork components but the total surface of repaired areas must not be more 10% of the total surface of the part.

If you have some doubt, don't hesitate to contact Mygale

4.1 4 BODYWORK ADJUSTMENT

To optimize sidepod adjustment, brackets on the floor and on the side of the monocoque can be adjusted.

For the engine cover, brackets on the rear face of the monocoque, on the rear roll hoop and on the gearbox can be adjusted.

Adjustable brackets are in red on the following drawing:

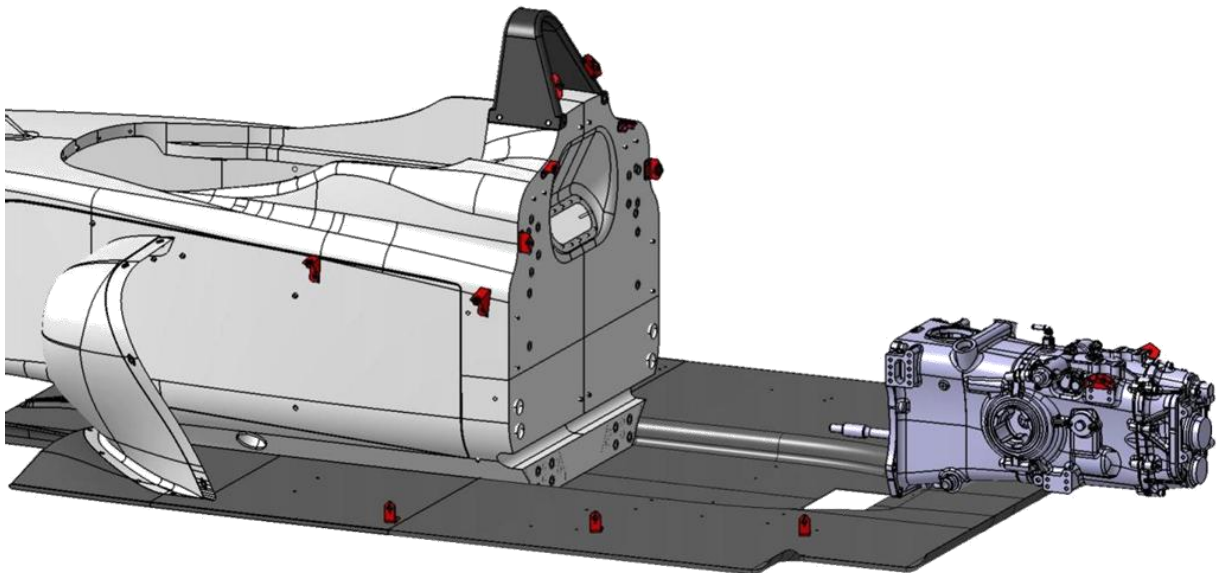

4.1 5 EXTRACTIBLE SEAT CUT FOR LOOM

In order to position correctly the extractable seat, it is allowed to make a local cut in the seat in the area of the chassis loom.

4.1 6 FIRE EXTINGUISHER

The fire extinguisher must be fitted in its support in the monocoque. Be sure that it is solidly attached by its retainer.

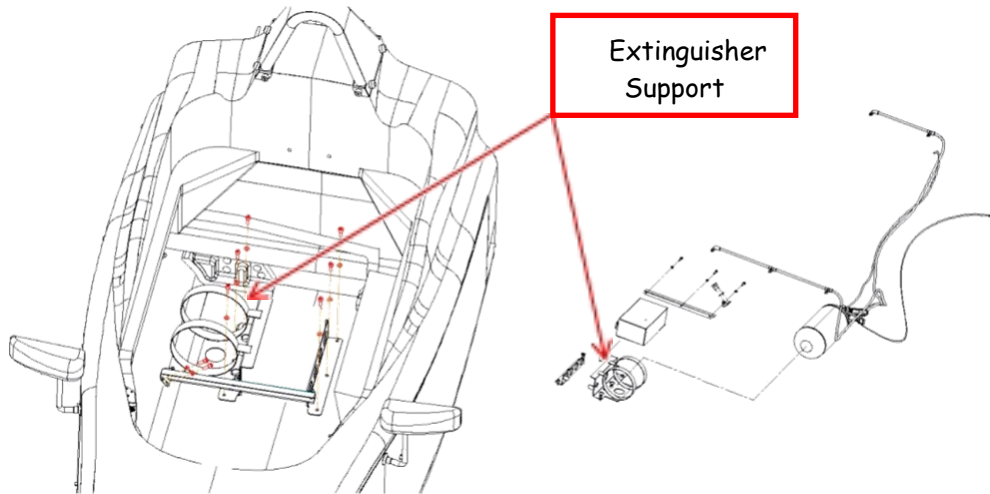

An interior pull handle cable is located on the right of the steering wheel. The exterior cable is located on the right of the rear rollover structure, and also activates the main master switch. Do not forget to add extinguisher and electrical switch stickers in this area, according to regulation. Eventually, Mygale proposes an extinguisher refill (ref: F.41.19.059.A).

A spacer F.41.19.061.A of 70mm is available as option in order to make the extinguisher cable handle easier to reach for the driver. Its length can be reduced by 24mm on the hole side of the spacer.

4. 1 7 MARKINGS AND HOLOGRAMS

Laser markings and holograms stickers must stay always visible and in any case must not be covered by painting or sticker. Furthermore, the holograms stickers must not be removed.

4. 1 8 SCREWS

The screws which are classified as type 2 can be modified but must keep the same class and dimensions as specified in the spares parts catalogue.

Concerned screws are those related to safety components:

- Front crashbox
- Rear roll hoop
- Rear crashbox/rear wing mount
- Seat belt
- Shoulder belt bracket

4. 1 9 FUEL SYSTEM

4. 1 9. 1 FUEL TANK

The fuel tank matches with the FIA specifications. All required details are issued in the certificate of compliance. (i.e. date of validation)

It is recommended to regularly wash the inside of the fuel tank to ensure there is no dirt in the fuel circuit. Mygale advises the team to clean the fuel cell and the fuel system after **the first uses**.

4. 1 9. 2 DRAIN

Do not use the car's fuel pump to drain the tank. It is advised to use an external pump in order to avoid damaging the on-board unit.

An external pump can be attached to the drain hole by removing the dash cap on the fuel tank plate. It is also necessary to open the filler cap while draining

Be careful not to damage the thread by over tightening the cap

Capacity: 48 litres

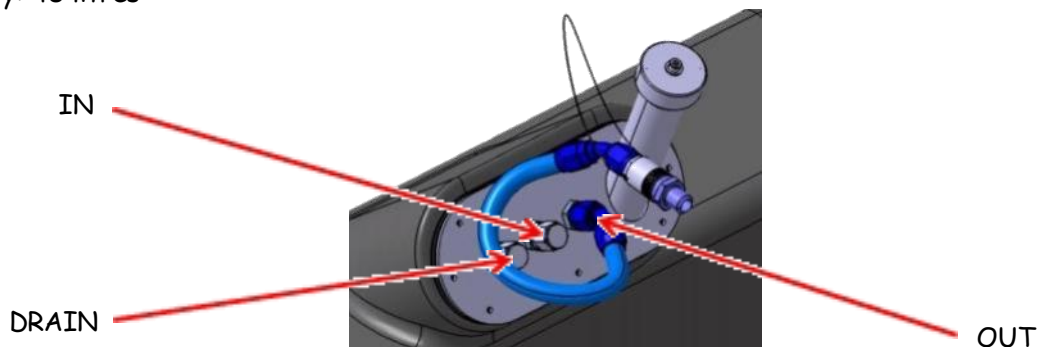

4. 1 9. 3 FUEL ASSEMBLY

The fuel pump assembly is composed of the fuel pump with its connector inside the fuel tank buffer body and two 3.5 bar pressure regulators.

In the bottom of the body are 3 check valves to fill the body with fuel.

When remounting the pump assembly, take care the pump and filter sock are positioned and attached with rilsan in order to keep free of move the 3 check valves, as illustrated on the following picture.

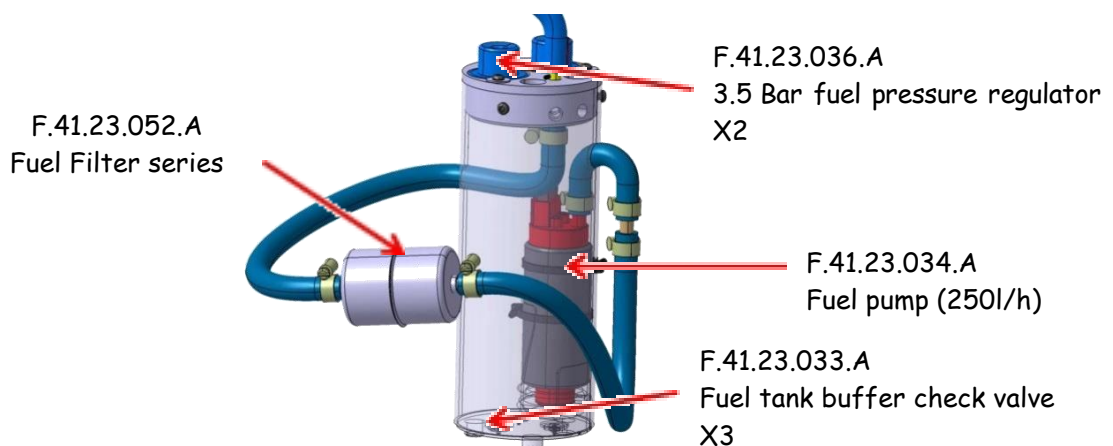

4.1 9. 4 SEALING

After all the gearbox and electric cables are insert in the monocoque, you must add expanded foam in the passage circled in red so as to ensure a sealing.

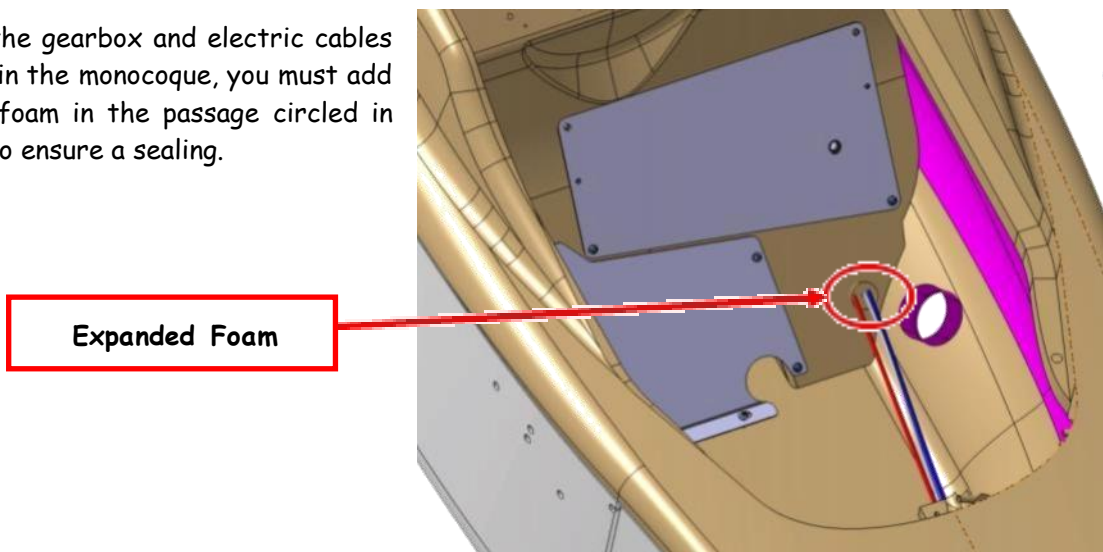

4. 20 COOLING SYSTEM

4. 20. 1 MAIN WATER CIRCUIT

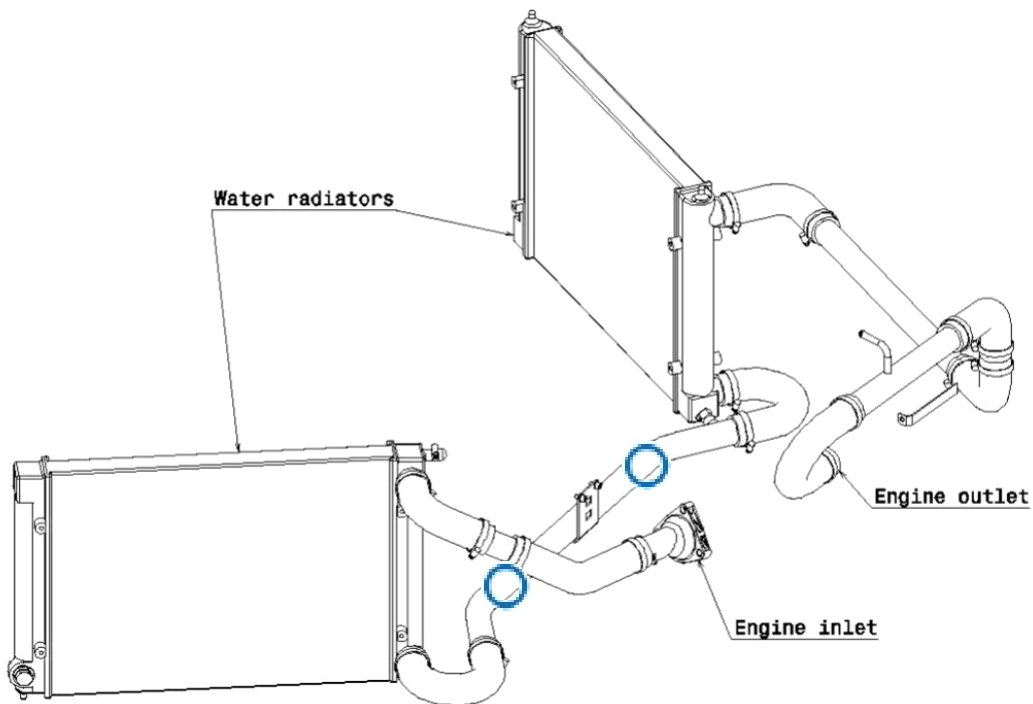

In order to make the mounting easier, it is allowed to cut or adjust the length of silicone hoses

It is recommended to add two cut parts of silicone hose D32 around the water tube that is between the two radiators, to get a better maintaining through the monocoque rear face (blue circles).

Warning: The right radiator cap must not be used to bleed the circuit. It must be manipulated carefully as the thread in the radiator is fragile. When mounting the cap, it is recommended to use sealing paste and tight moderately.

4. 20. 2 HEADER TANK CIRCUIT

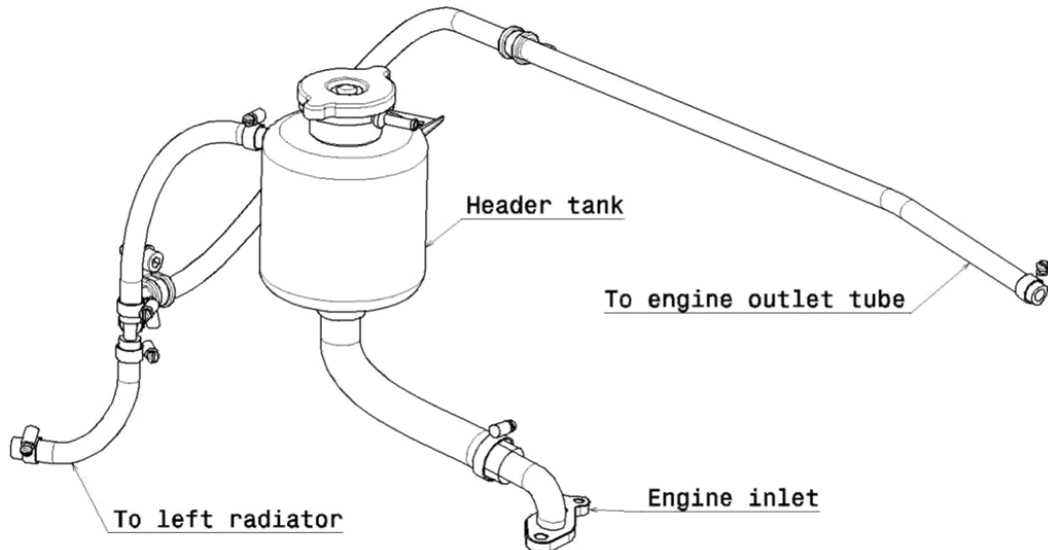

4. 20. 3 OIL CIRCUIT

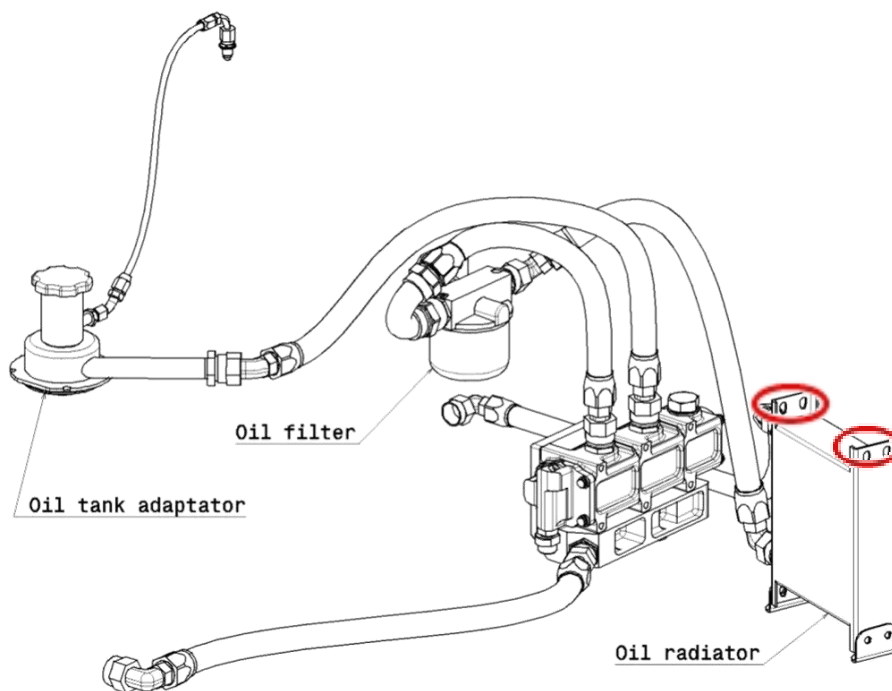

Nota: The two extensions surrounded in red on the picture can be cut by the team.

4. 20. 4 CATCH TANK

A catch tank is fitted in the car with its bracket, on the monocoque rear face.

To avoid any risk of oil in the water circuit, ensure that the catch tank hoses do not end at the bottom of the catch tank. The recommended position of hoses is at the middle height of the catch tank (see following picture).

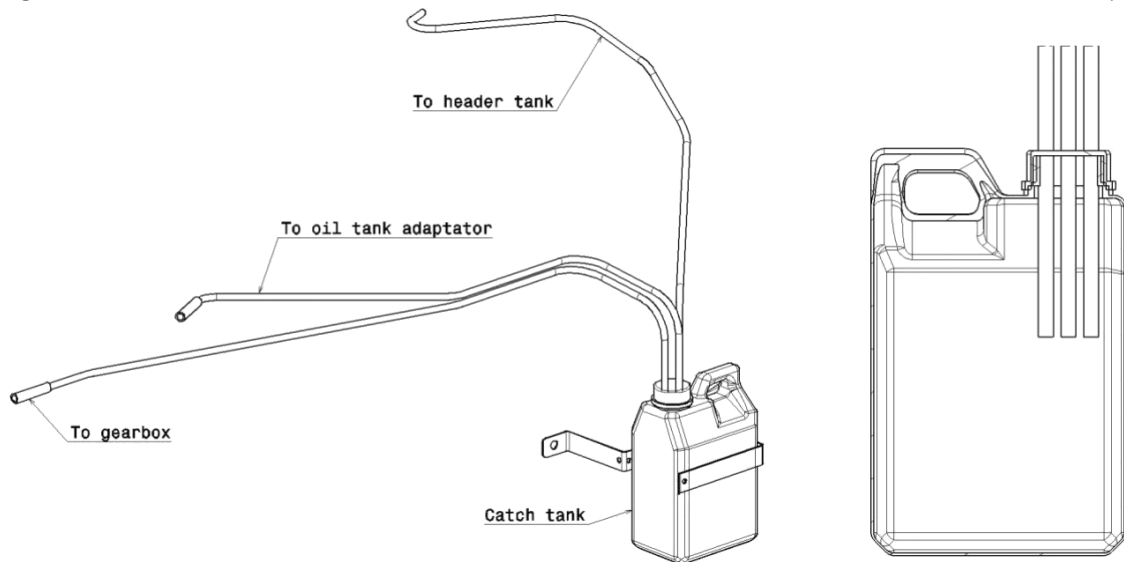

4. 21 FILLING FLUIDS

The recommended quantities must always be respected.

Designation	Brand	Quality	Quantity
Engine Oil	Motul	540	5L
Gear box Oil	Motul (blue)	75W140	1.3 L
Water cooling	Castrol	Anti freeze	6 L (50% extract - 50% water)
Brake fluid / Clutch release fluid	Castrol	SRF	2 L
Fuel	-	Unleaded 98 or 95	48 L

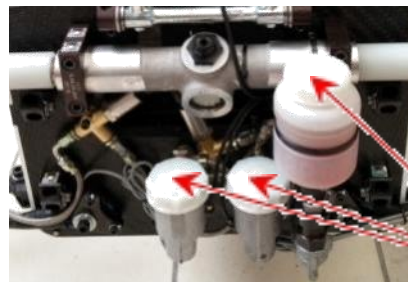

4. 22 ACCIDENT DATA RECORDER

An ADR (Accident Data Recorder) can be fitted in the car. This ADR can be mounted under the extractable seat (reference F.41.19.030.A) as explained on the following picture.

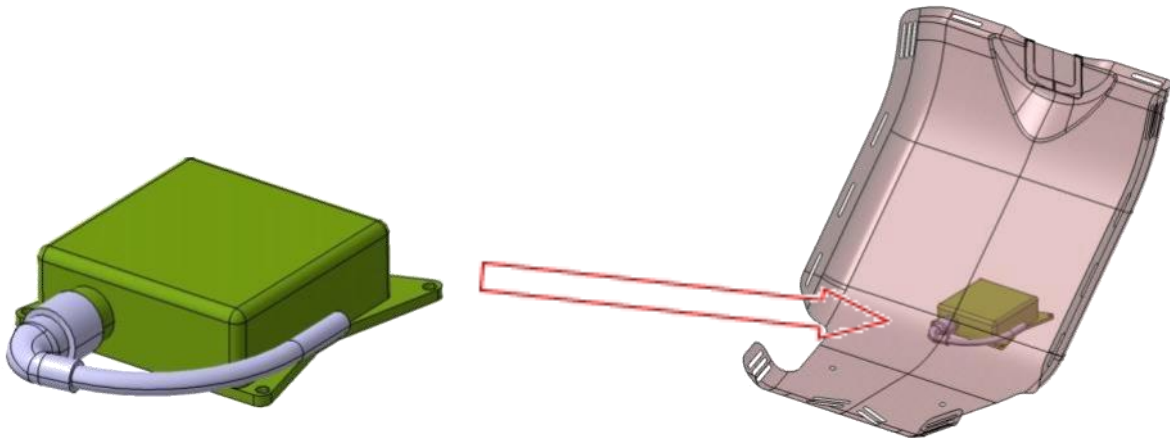

4. 23 ASSEMBLY OF THE STARTER

In the case of a Clutch Housing with a C index (or previous), the team must insert the spacer F.41.12.077.A between the starter and the housing.

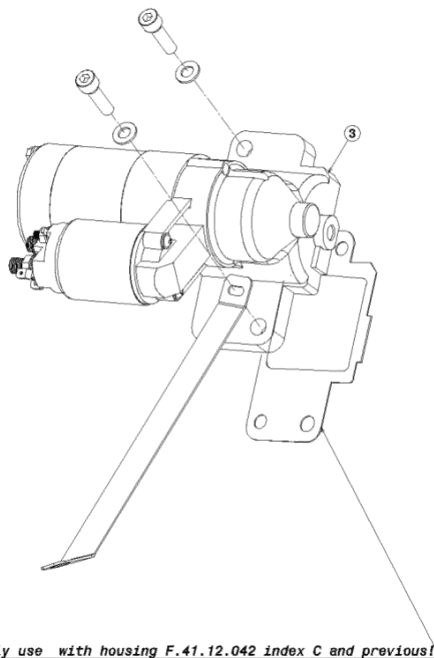

Only use with housing F.41.12.042 index C and previous!

4. 24 EXPLOITATION TOOLS

4.24. 1 JACK BAR

About the teams who want to build their own jack bar, Mygale provides some dimensions to them.

FRONT DIMENSIONS

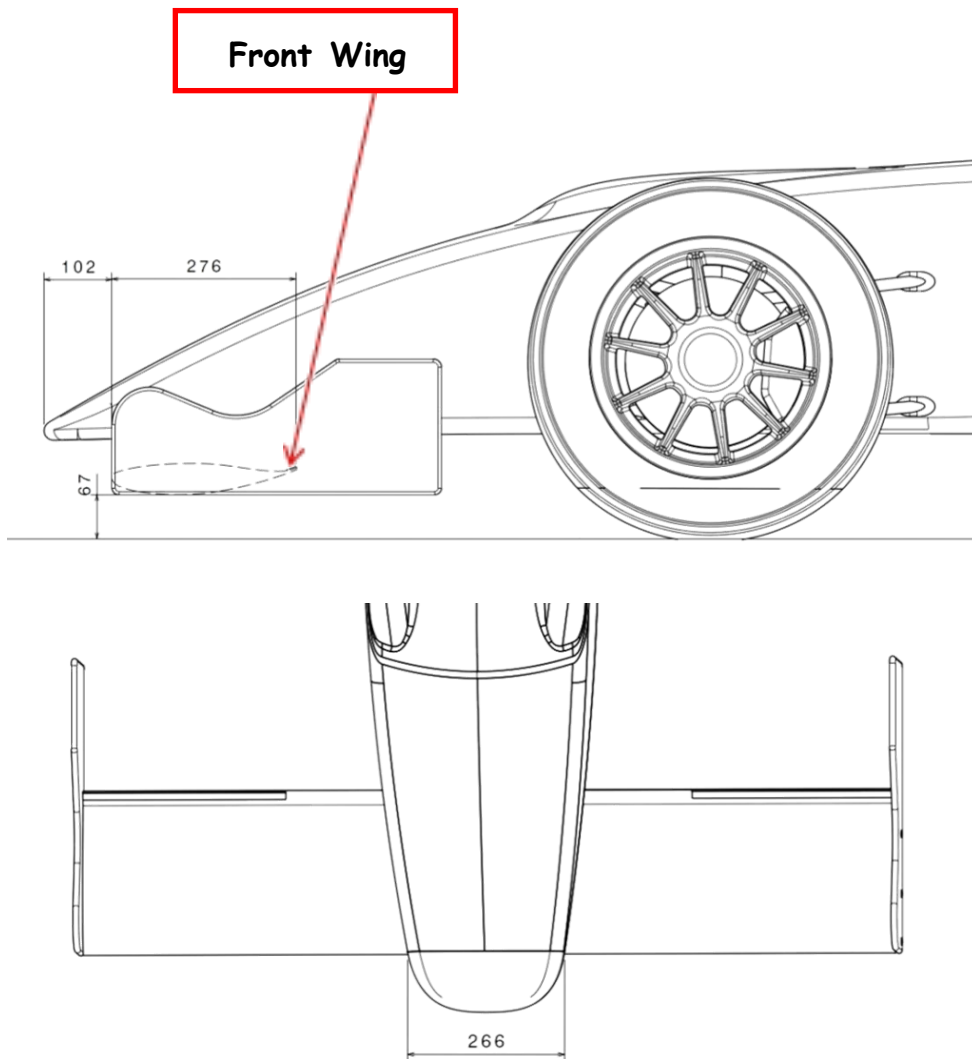

REAR DIMENSIONS

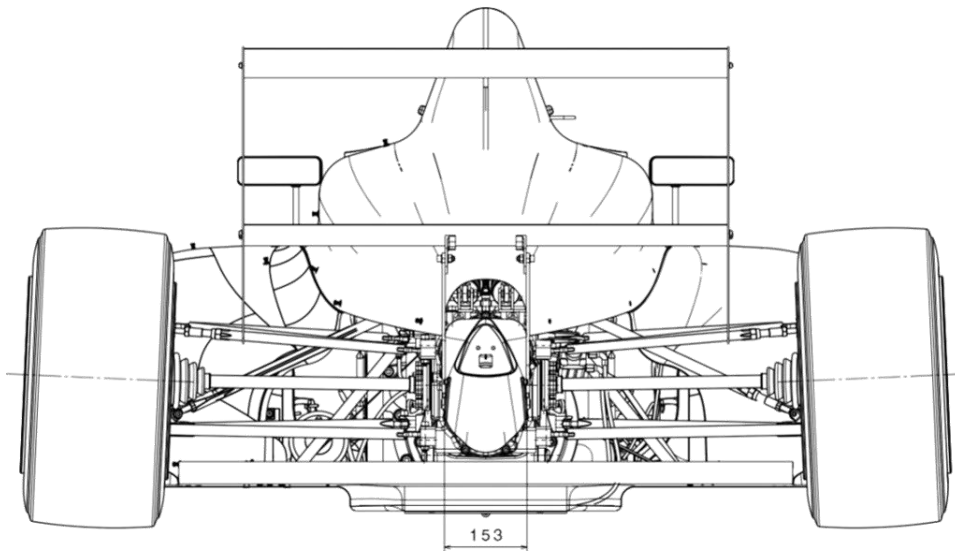
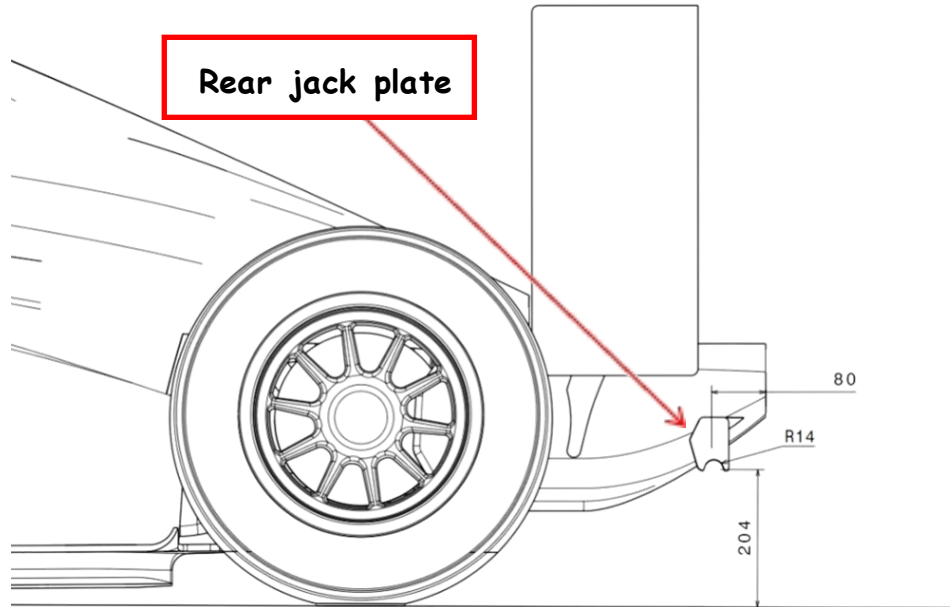

Mygale also proposes its own jack bars. These ones are available on the spare parts catalogue:

Front jack bar (F.41.35.008)



Rear jack bar (F.41.35.020)

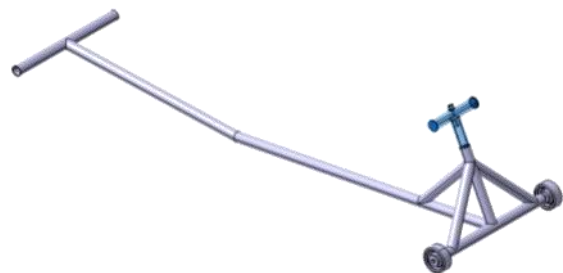

4.24. 2 SET UP TOOLS

Some basic set-up tools are for sale on the spare parts catalogue. Tools to adjust parallelism are available:

Front parallelism bar (F.41.35.026)

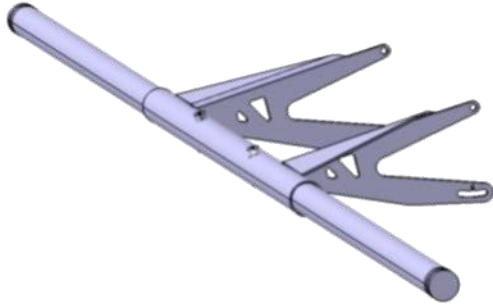

Rear parallelism bar (F.41.35.027)

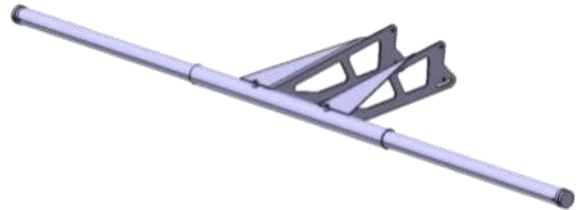

We also propose false wheels which help you to set your car. The height of this part is adjustable so as to simulate your real wheel.

False wheel (F.41.35.066)

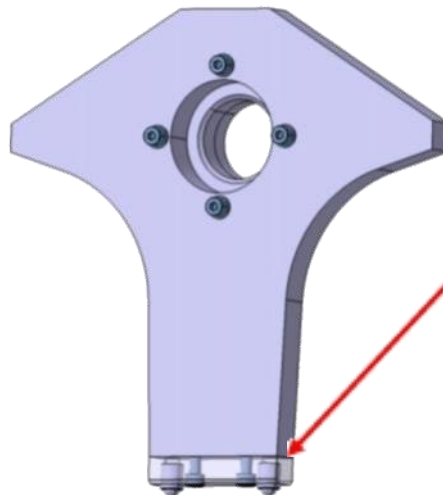

**Height adjusters
can be insert there**

The references of the adjusters are: - 1mm adjuster: F.41.35.032
- 2 mm adjuster: F.41.35.035
- 3 mm adjuster: F.41.35.033

4.24. 3 VARIOUS TOOLS

Mygale is able to propose useful tools like:

Body support trestles (F.41.35.054)

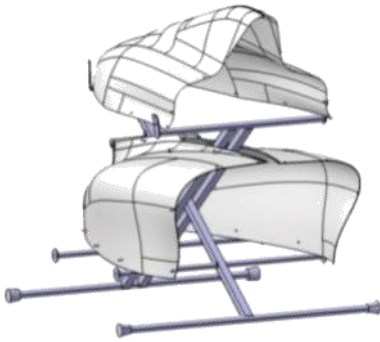

Steering wheel support (F.41.35.127)



Fuel filler cask (F.41.35.105) and its support (F.41.35.110)

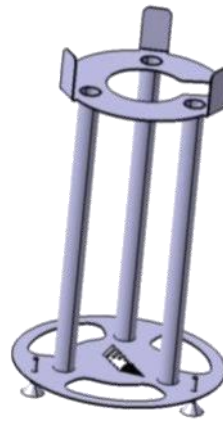

Holding key (F.41.35.060) and socket to fix your wheels studs (F.41.35.124)

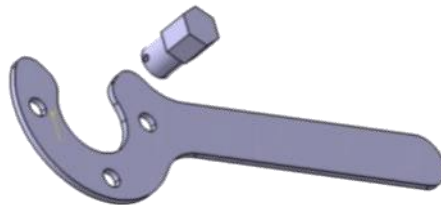

5.0 ANNEXES

5.1 TIGHTENING TORQUES (GENERAL)

General guideline for tightening torques for steel bolts:

METRIC				
Coarse Thread Bolt				
		8.8	10.9	12.9
Thread	Pitch	Torque	Torque	Torque
		Nm	Nm	Nm
M4	0.7	2.5	3.5	4.2
M5	0.8	4.9	6.9	8.3
M6	1	8.4	11.9	14
M8	1.25	20	28	34
M10	1.5	40	55	65
M12	1.75	70	100	115
M14	2	110	150	180
Fine Thread Bolt				
		8.8	10.9	12.9
Thread	Pitch	Torque	Torque	Torque
		Nm	Nm	Nm
M8	1.0	22	30	36
M10	1.0	44	62	75
M10	1.25	42	59	72
M12	1.25	75	105	130
M12	1.5	70	100	120
M14	1.5	120	170	200
M16	1.5	180	250	300
M18	1.5	260	370	440
M20	1.5	360	510	610
IMPERIAL				
		Grade 5	Grade 8	
Thread	Pitch	Torque	Torque	
		Lbs-ft	Lbs-ft	
1/4	28 TPI	7	10	
5/16	24 TPI	14	20	
3/8	24 TPI	25	35	
7/16	20 TPI	40	55	
1/2	20 TPI	60	85	
9/16	18 TPI	85	120	
5/8	18 TPI	120	170	

These values should be used where a different torque value is not specified.

This data refer to a friction coefficient = 0.1 (lubricated). For different friction values the data can change considerably. For example, considering a friction of 0.14 the preload will decrease by about 7% while the torque force will increase about 25%.

Conversion factors:

- Lbs-ft x 1.356 = Nm
- Nm x 0.7376 = Lbs-ft

5.2 TIGHTENING TORQUES (F4 MOUNTING)

TIGHTENING TORQUES					
Désignation	Size	Tightening torque			Notes
		N.m (x9.81)	m.Kg	Lb.Ft (x par 7.246)	
Wheel - Suspension - Upright					
Wheel nut	20 x 1.00	200	20.4	147.5	Loctite
Wheel peg	12 x 1.5	115	11.7	85	
Wheel bearing	12 x 1.5	115	11.7	85	
Rocker bolts	10 x 1.5	65	6.6	48	
Lower wishbone outer bearing	3/8-24 UNF	35	3.6	26	
Suspension bearings	8 x 1.25	34	3.5	25	
Suspension brackets	8 x 1.25	34	3.5	25	
Wheel cables	8 x 1.25	34	3.5	25	
Gear box / clutch / Bell housing					
Clutch	8 x 1.25	34	3.5	25	
Bell housing upper	12 x 1.75	115	11.7	85	
Bell housing lower	10 x 1.5	65	6.6	48	
Gearbox	10 x 1.5	65	6.6	48	
Brake					
Calliper bolt	10 x 1.5	70	7.1	52	
Engine					
Lower engine fitting	10 x 1.5	65	6.6	48	
Upper engine fitting	8 x 1,25	34	3.5	25	

COMPONENTS LIFE CYCLE AND GUARANTEE

The components of this vehicle have a limited life cycle and it returns to the holder to assure the maintenance and checking. The maximum mileage of the parts is set to one season (tests and races), and after this period, Mygale recommends to replace all the parts exposed to a possible fatigue weakening.

It is strongly recommended to replace all the parts that could be affected / damaged after a major crash or accident.

The wear parts have to be replaced according to the holder's appreciation.

Moreover, all the "competition" parts cannot be covered by any contractual guarantee.

MYGALE CONTACT LIST

Web site: www.mygale.fr

Parts sales: spareparts@mygale.fr

Technical information: engineering@mygale.fr

Telephone: +33 (0)386 21 86 21

Fax : +33 (0)386 21 86 22



网站: www.FIAF4.com.cn 电话: 82334882/82334883 传真: 82334882 邮编: 100191
组委会地址: 北京市海淀区知春路1号学院国际大厦609室

Room609, XueYuan International Tower no. 1, Zhichun Road, Haidian District Beijing 100191 China